

PROJECT	DESIGNATION
2001172 & 2100049	2001172 & 2100049
CONTRACT	
R-42909	

INDIANA DEPARTMENT OF TRANSPORTATION

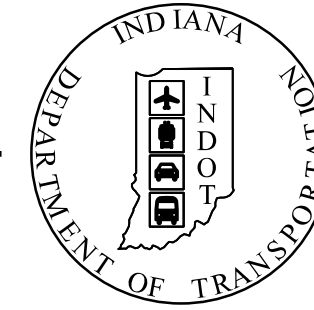

ROAD PLANS I-65 ADDED TRAVEL LANES

ROUTE: I-65 FROM: RP 178+0.56 TO: RP 180+0.75
PROJECT NO. 2001172 & 2100049 P.E.
2001172 & 2100049 CONST.

SEE SHEET IN-01 FOR
TRAFFIC AND DESIGN DATA

KIN PROJECT INFORMATION		
DESIGNATION	PROJECT DESCRIPTION	
ROAD		
2001172	ADDED TRAVEL LANES FROM 1.33 MILES NORTH OF SR 25 TO 0.8 MILE NORTH OF SR 43 RP'S 178+0.56 TO 179+0.95.	LEAD DES.
2100049	ADDED TRAVEL LANES FROM 0.8 MILE NORTH OF SR 43 TO 2.43 MILES NORTH OF SR 43 AND RP'S 179+0.95 TO 180+0.75.	
BRIDGE		
2002114	I-65 NB OVER CSX R.R., 9TH STREET, AND BURNETTS CREEK	
2002115	I-65 SB OVER CSX R.R., 9TH STREET, AND BURNETTS CREEK	
1601088	I-65 NB OVER SR 43	
1601090	I-65 SB OVER SR 43	
2002116	I-65 NB OVER PROPHETS ROCK ROAD	
2002117	I-65 SB OVER PROPHETS ROCK ROAD	
2002364	CR 725 N OVER I-65	

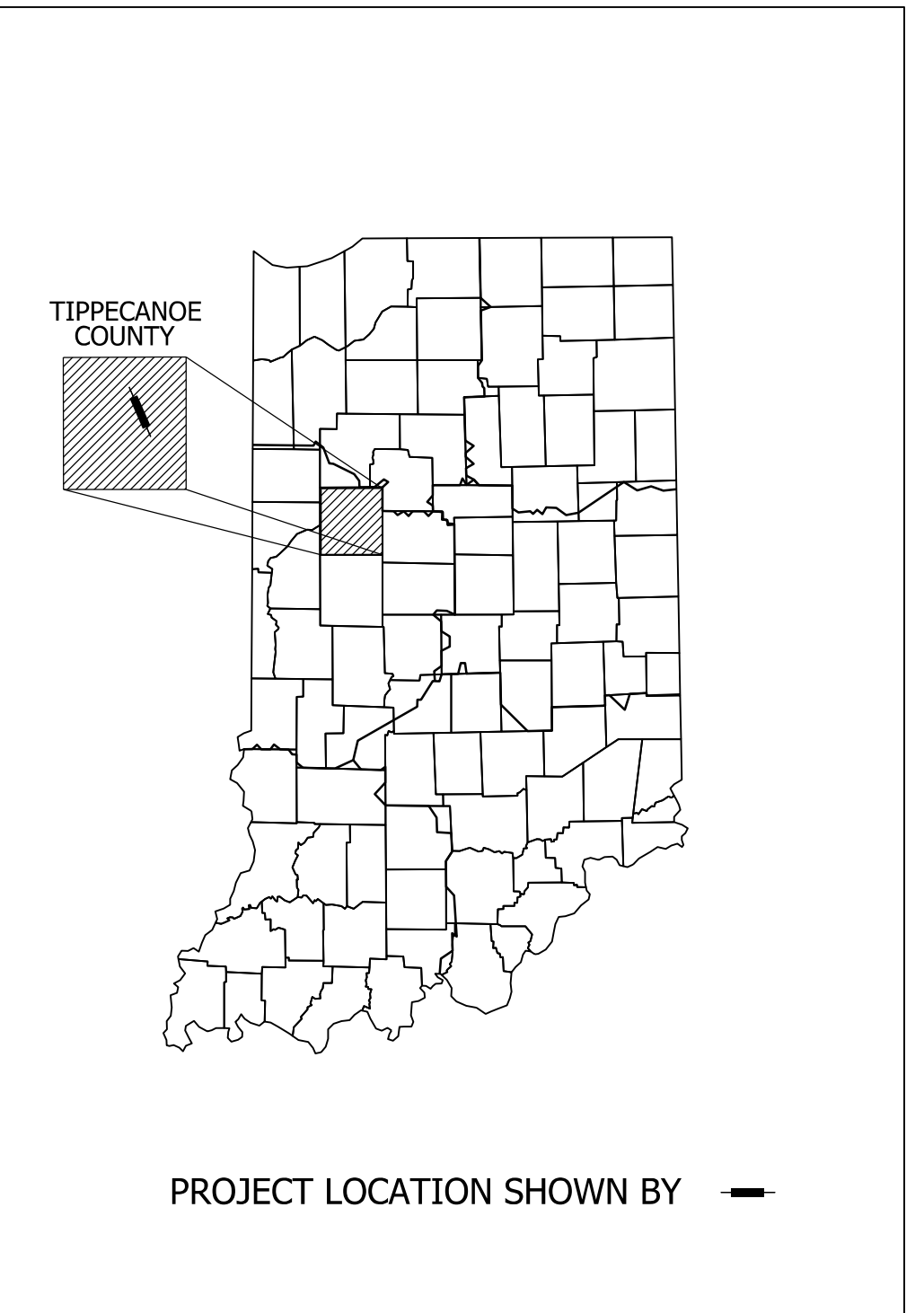

PROJECT LOCATION SHOWN BY —

END PROJECT
PROJECT NO. 2001172
P.O.C. STA. 209+08.64
LINE "PR-65-SB"
P.O.C. STA. 309+03.46
LINE "PR-65-NB"

BEGIN PROJECT
PROJECT NO. 2001172
STA. 822+10.00
LINE "PR-A"

BEGIN INCIDENTAL
CONSTRUCTION
PROJECT NO. 2001172
STA. 812+60.00
LINE "PR-A"

PROJECT DESCRIPTION

ADDED TRAVEL LANES AND ROADWAY RECONSTRUCTION ON I-65 EXTENDS 4.04 MILES ALONG INTERSTATE 65 STARTING FROM 1.33 MILES NORTH OF THE STATE ROAD 25 INTERCHANGE TO 2.43 MILES NORTH OF STATE ROAD 43 INTERCHANGE, IN SECTIONS 17, 20, 21, 27, 28 & BURNETT'S RESERVE, TOWNSHIP 24 NORTH, RANGE 4 WEST, IN TIPPECANOE TOWNSHIP, TIPPECANOE COUNTY, INDIANA.

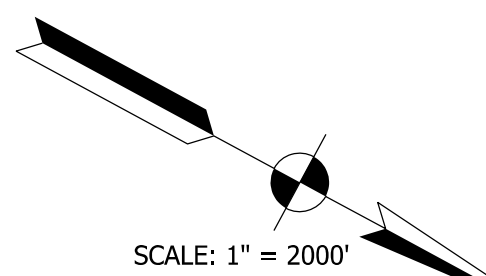
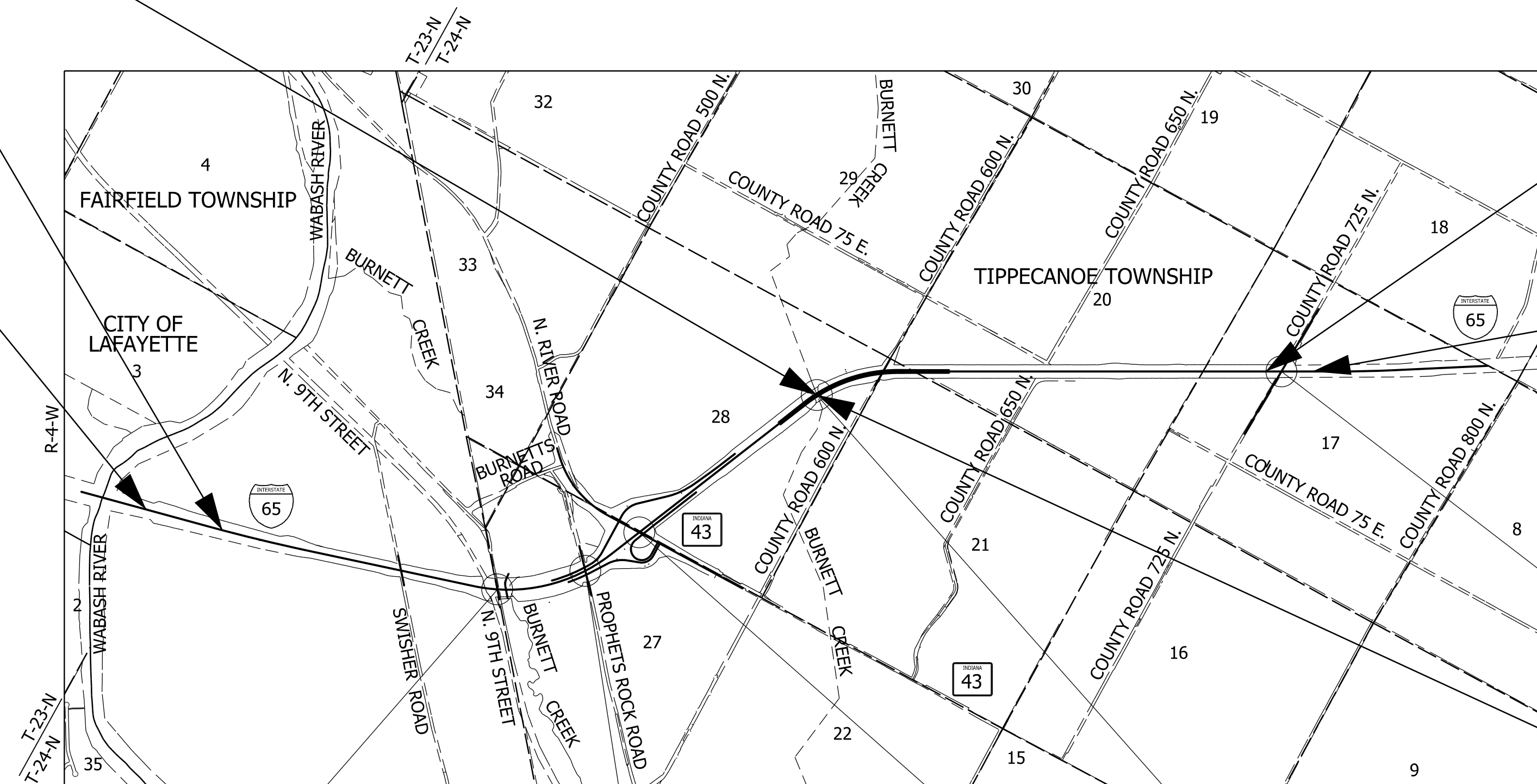

END PROJECT
PROJECT NO. 2100049
STA. 1036+03.00
LINE "PR-A"

END INCIDENTAL
CONSTRUCTION
PROJECT NO. 2100049
STA. 1053+70.00
LINE "PR-A"

LATITUDE: 40°29'49" LONGITUDE: 86°52'06"

HYDROLOGIC UNIT CODE: 05120105070030
05120108010030
05120108010010
05120108010020

GROSS LENGTH: 4.04 MI.
NET LENGTH: 3.81 MI.
MAX. GRADE: 3.04 %

NO ADDITIONAL R/W REQUIRED
FOR THIS CONTRACT

BRIDGE FILE NO.
165-180-05489
CR 725 N OVER I-65

BEGIN PROJECT
PROJECT NO. 2100049
P.O.C. STA. 209+08.64
LINE "PR-65-SB"
P.O.C. STA. 309+03.46
LINE "PR-65-NB"

BRIDGE FILE NO.
165-177-02402 BNBL
165-177-02402 JCSB
I-65 OVER CSX R.R., 9TH STREET
AND BURNETTS CREEK

BRIDGE FILE NO.
165-178-05485 BNBL
165-178-05485 JBSB
I-65 OVER PROPHETS ROCK ROAD

LOCATION MAP
TIPPECANOE TOWNSHIP
TIPPECANOE COUNTY

BRIDGE FILE NO.
165-178-05486 JCNB
165-178-05486 CSBL
I-65 OVER SR 43

BRIDGE FILE NO.
165-179-05487 CNBL
165-179-05487 CSBL
I-65 OVER BURNETTS CREEK
(Work By Others)

INDIANA DEPARTMENT OF TRANSPORTATION
STANDARD SPECIFICATIONS DATED 2020
TO BE USED WITH THESE PLANS

STAGE 2 PLANS
FEBRUARY 1, 2021



HNTB CORPORATION
THE HNTB COMPANIES
ENGINEERS ARCHITECTS PLANNERS
111 MONUMENT CIRCLE
SUITE 1200
INDIANAPOLIS, IN 46204

DRAFT
NOT FOR CONSTRUCTION

PLANS PREPARED BY: _____ PHONE NUMBER _____
CERTIFIED BY: _____ DATE _____
APPROVED FOR LETTING: _____ DATE _____
INDIANA DEPARTMENT OF TRANSPORTATION

BRIDGE FILE	
N/A	
DESIGNATION	
2001172 & 2100049	
SURVEY BOOK	SHEETS
ELECTRONIC	1 of 536
CONTRACT	
PROJECT	
R-42909	2001172 & 2100049

rstriegel
9/29/2020 12:02:59 pm
model-sheet1
file: c:\cadd\ib\p\hntb_dkaskie\greatlakes\02-10385\2001172-nd-ss-cov01.dgn

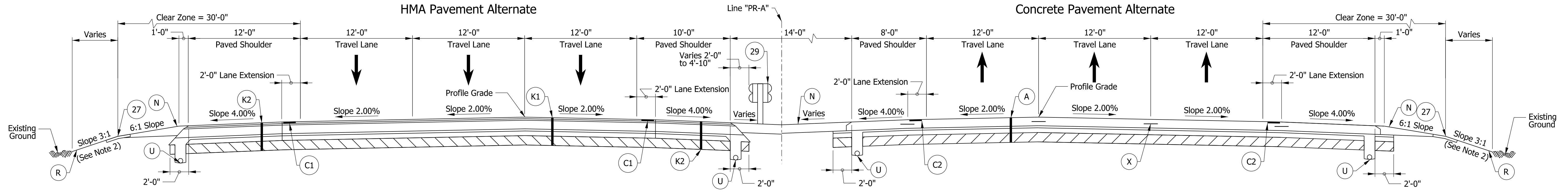

I-65 NORMAL CROWN TYPICAL SECTION
 STA. 822+10.00 "PR-A" to STA. 824+71.00 "PR-A"

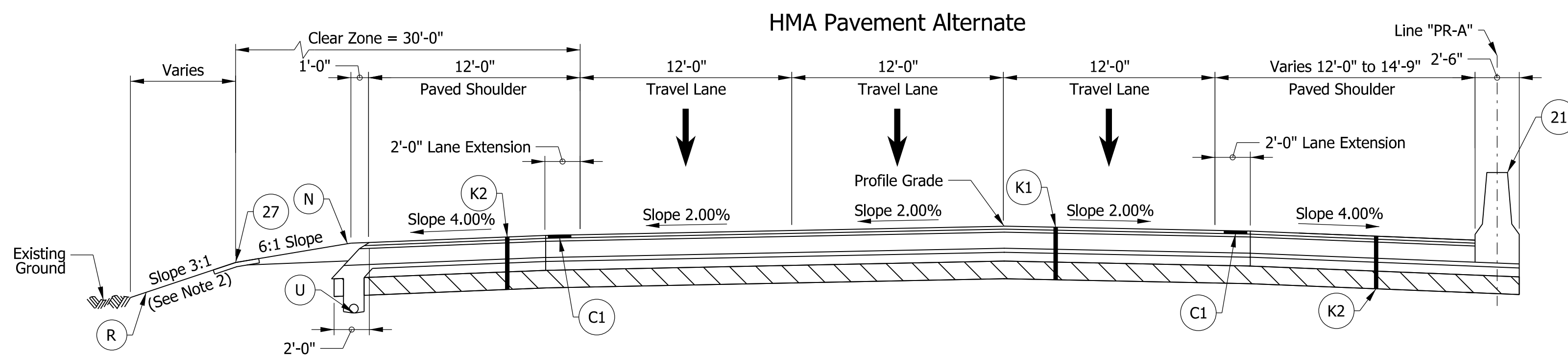

I-65 NORMAL CROWN TYPICAL SECTION
 STA. 824+71.00 "PR-A" to STA. 828+21.00 "PR-A"

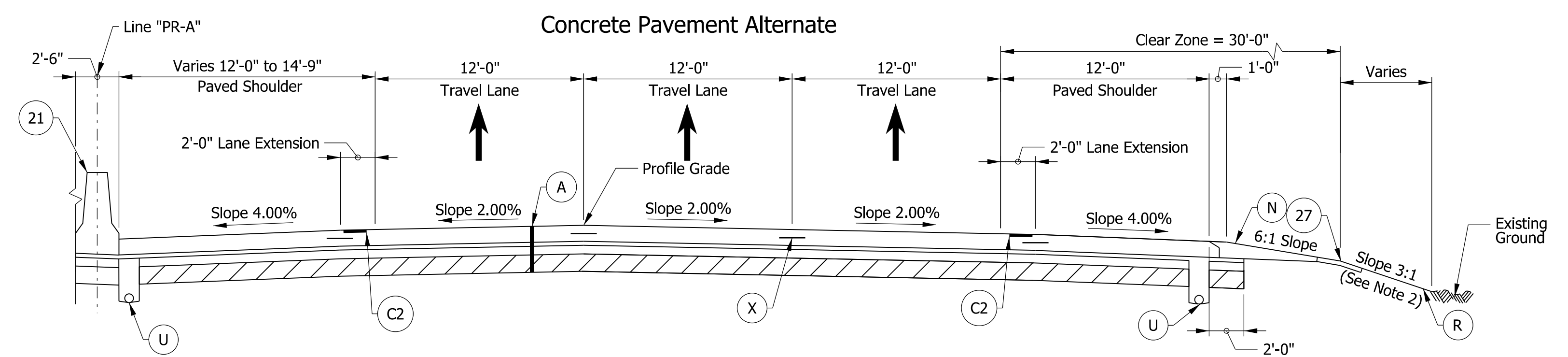

I-65 NORMAL CROWN TYPICAL SECTION
 STA. 824+71.00 "PR-A" to STA. 828+21.00 "PR-A"

- Notes:
1. See DET-01 for Legend and Variable Width Table.
 2. See Cross Sections for varying slopes.

NOTE TO REVIEWER:

Pavement design assumed to be asphalt for estimating purposes. Pavement design to be approved in a future submittal.

NOTE TO REVIEWER:

Safety Edge detail to be provided in a future submittal.

DRAFT
 NOT FOR CONSTRUCTION

RECOMMENDED FOR APPROVAL	DESIGN ENGINEER	DATE
DESIGNED: _____	DCK	DRAWN: _____
CHECKED: _____	MKM	CHECKED: _____
	MKM	

INDIANA
 DEPARTMENT OF TRANSPORTATION

TYPICAL CROSS SECTIONS
 I-65 LINE "PR-A"

HORIZONTAL SCALE	BRIDGE FILE
3/16"=1'-0"	N/A
VERTICAL SCALE	DESIGNATION
N/A	2001172 & 2100049
SURVEY BOOK	SHEETS
ELECTRONIC	4 of 536
CONTRACT	PROJECT
R-42909	2001172 & 2100049

rstriegel
 1/20/2021 10:46:33 am
 model:Sheet4
 file:c:\caddlib\pwr\rstriegel\pwr\grat_lakes\02-40385\2001172-rd-s-hyrd1.dgn

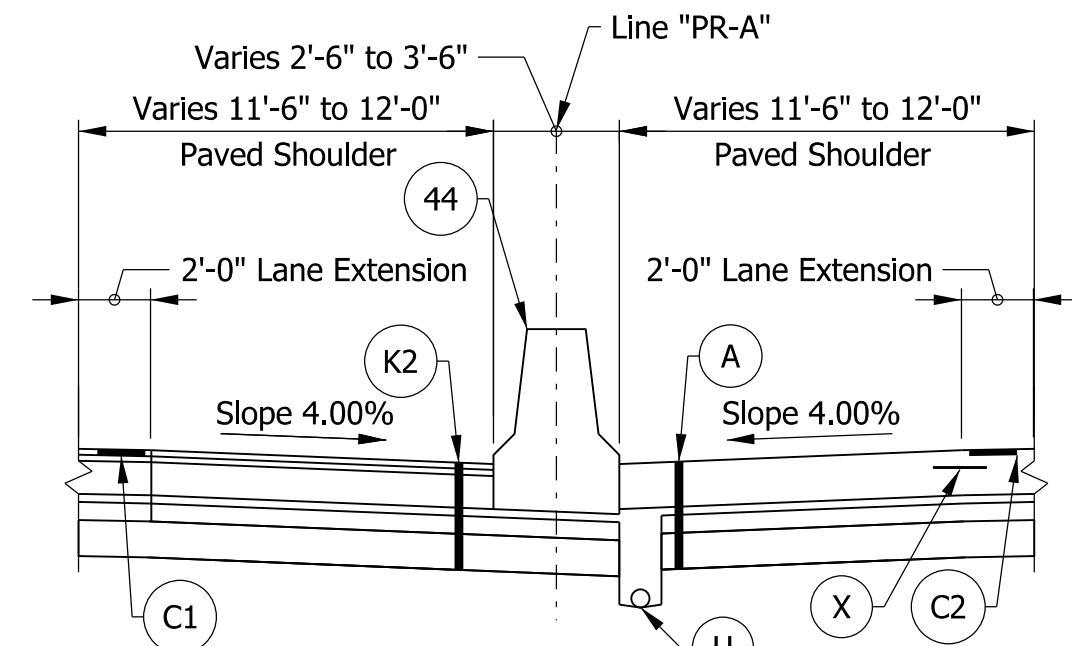

MODIFIED MEDIAN BARRIER DETAIL
 STA. 856+64.00 "PR-A" to STA. 857+75.00 "PR-A"
 STA. 904+68.00 "PR-A" to STA. 907+75.00 "PR-A" *
 STA. 993+97.00 "PR-A" to STA. 994+83.00 "PR-A"

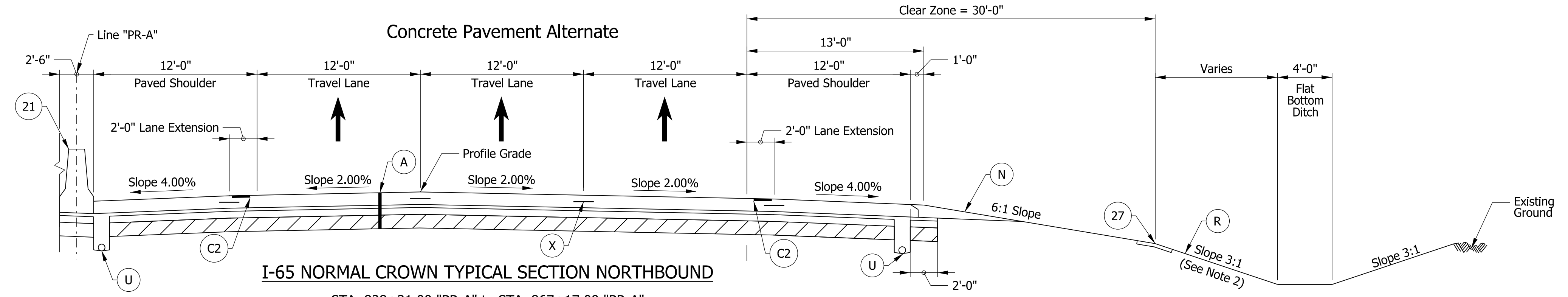

I-65 NORMAL CROWN TYPICAL SECTION NORTHBOUND
 A STA. 828+21.00 "PR-A" to STA. 867+17.00 "PR-A"
 STA. 903+41.00 "PR-A" to STA. 940+10.00 "PR-A"
 STA. 975+45.00 "PR-A" to STA. 1029+20.00 "PR-A"

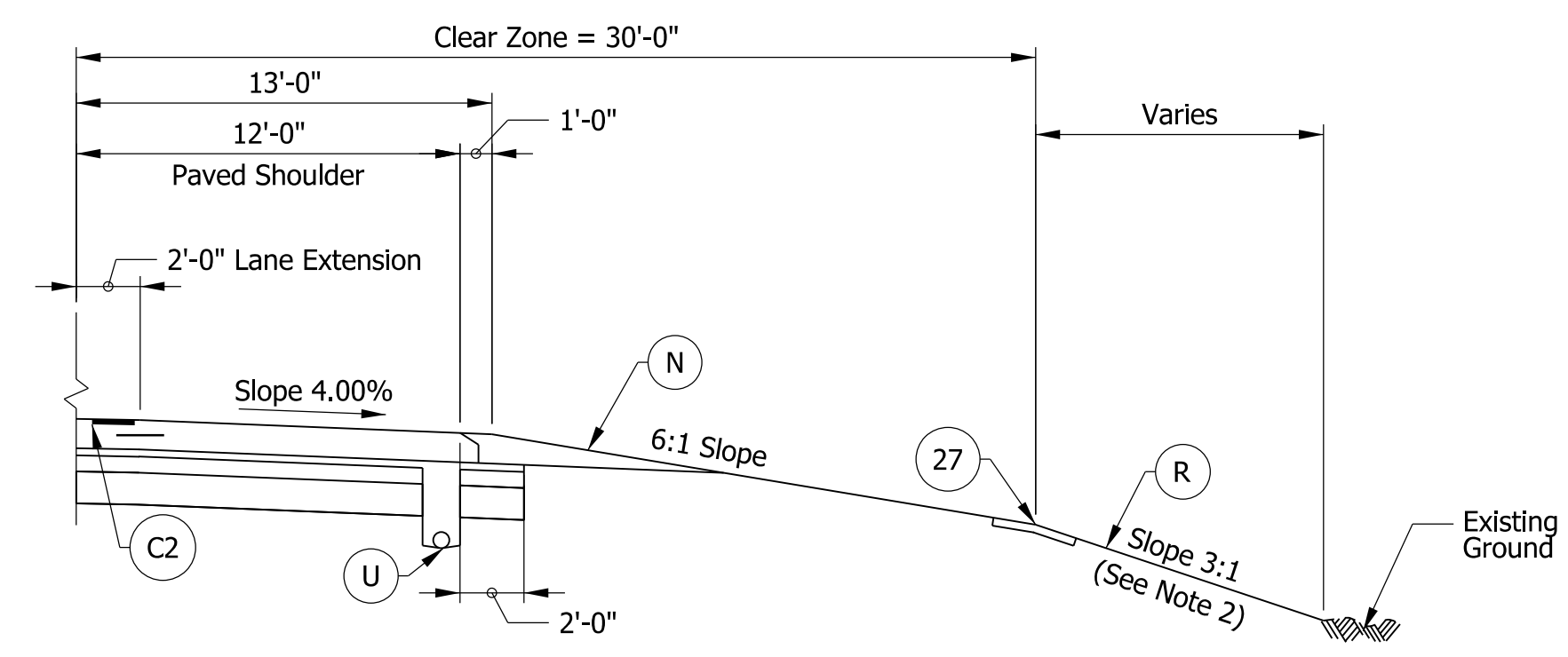

NB OUTSIDE SHOULDER DETAIL
 STA. 828+21.00 "PR-A" to STA. 834+00.00 "PR-A" NB
 STA. 935+00.00 "PR-A" to STA. 940+10.00 "PR-A" NB
 STA. 989+50.00 "PR-A" to STA. 1016+50.00 "PR-A" NB

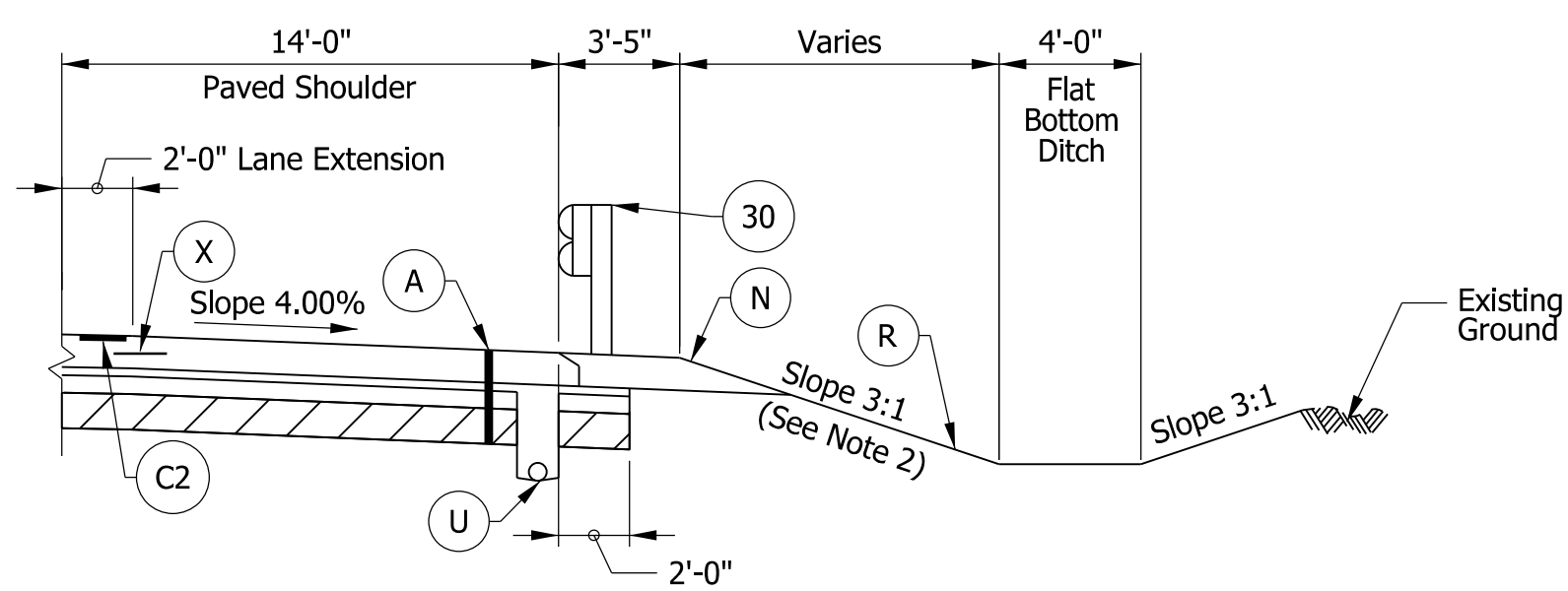

NB GUARDRAIL AND OUTSIDE SHOULDER DETAIL
 STA. 855+05.00 "PR-A" to STA. 857+98.75 "PR-A" NB

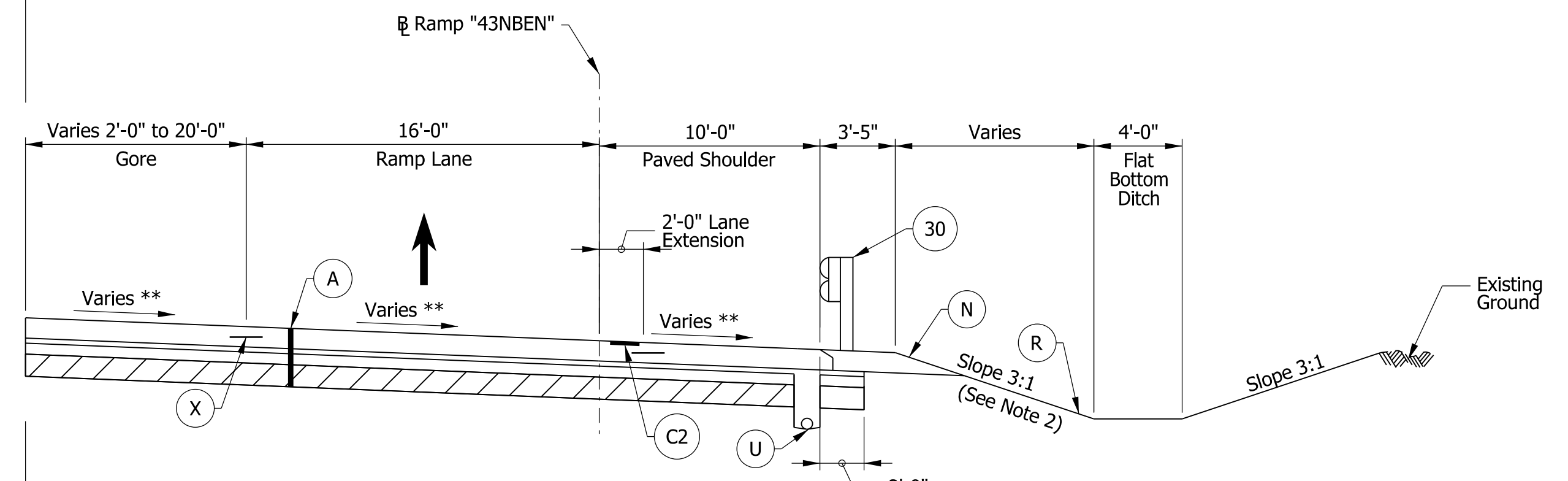

RAMP GORE SECTION WITH GUARDRAIL- I-65 NORTHBOUND AT SR 43
 STA. 903+84.07 "PR-A" to STA. 907+87.76 "PR-A"

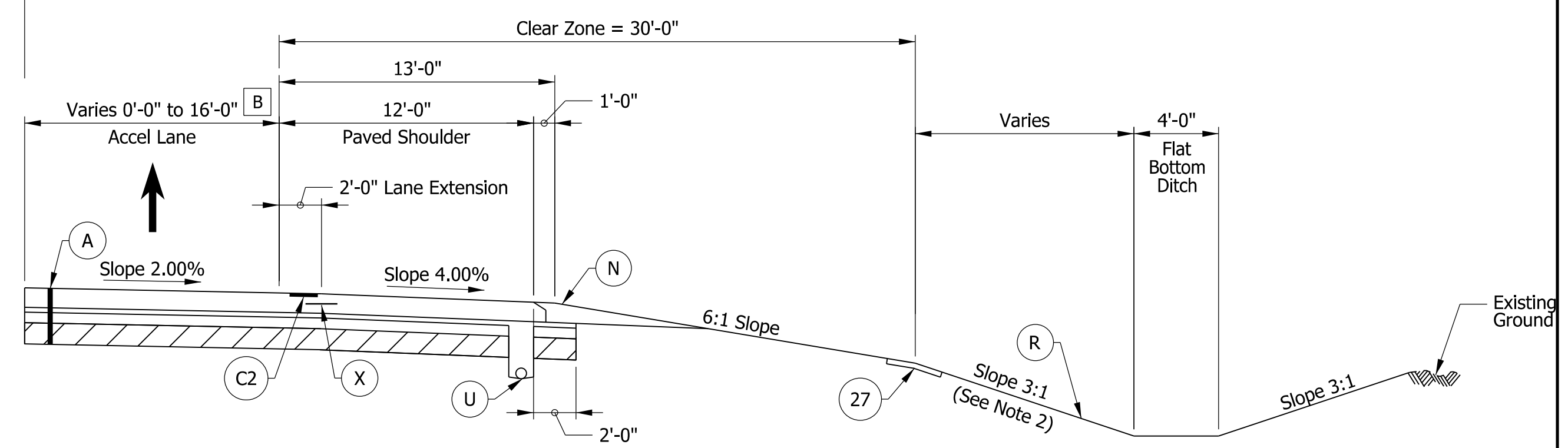

ACCELERATION LANE - I-65 NORTHBOUND AT SR 43
 STA. 907+87.76 "PR-A" to STA. 927+97.00 "PR-A"

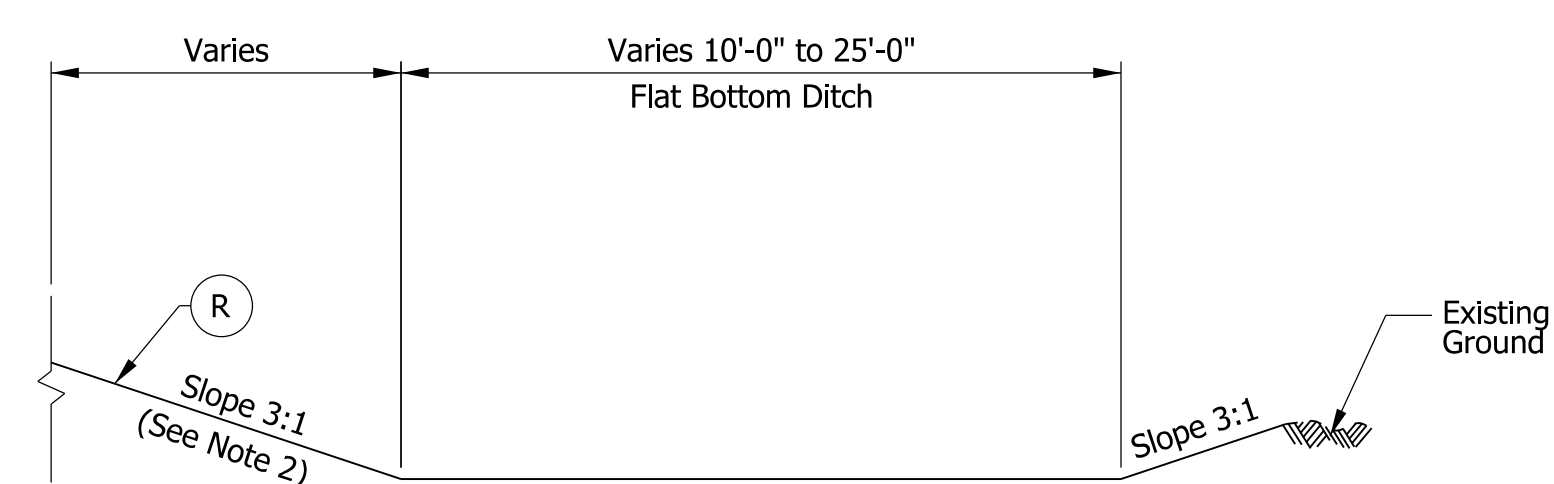

OUTSIDE WIDE DITCH DETAIL
 STA. 847+00.00 "PR-A" to STA. 853+00.00 "PR-A" NB
 STA. 860+50.00 "PR-A" to STA. 863+00.00 "PR-A" NB
 STA. 923+50.00 "PR-A" to STA. 929+50.00 "PR-A" NB

- A NB Bridge Paving Exception from STA. 905+27.30 "PR-A" to STA. 907+46.96 "PR-A"
- B See Construction Detail sheets for limits of acceleration and deceleration lanes and taper limits.

- Notes:**
- See DET-01 for Legend and Variable Width Table.
 - See Cross Sections for varying slopes.
 - Proposed improvements to follow "PR-65-NB" and "PR-65-SB" between STA. 940+10.00 "PR-A" and STA. 975+45.00 "PR-A".
- * Slope varies. See shoulder transition exhibits.
 ** Slope varies. See Gore Details.

NOTE TO REVIEWER:
 Pavement design assumed to be asphalt for estimating purposes. Pavement design to be approved in a future submittal.

NOTE TO REVIEWER:
 Safety Edge detail to be provided in a future submittal.

DRAFT
 NOT FOR CONSTRUCTION

RECOMMENDED FOR APPROVAL _____	DESIGN ENGINEER _____	DATE _____
DESIGNED: _____ DCK _____	DRAWN: _____ DCK _____	
CHECKED: _____ MKM _____	CHECKED: _____ MKM _____	

INDIANA
 DEPARTMENT OF TRANSPORTATION

TYPICAL CROSS SECTIONS
 I-65 LINE "PR-A"

HORIZONTAL SCALE	BRIDGE FILE
3/16"=1'-0"	N/A
VERTICAL SCALE	DESIGNATION
N/A	2001172 & 2100049
SURVEY BOOK	SHEETS
ELECTRONIC	5 of 536
CONTRACT	PROJECT
R-42909	2001172 & 2100049

rstriguel
 1/20/2021 10:46:34 am
 model: Sheets5
 file: c:\candib\pwr\striguel\pwr\great_lakes\02\40385\2001172-rd-s-hyp01.dgn

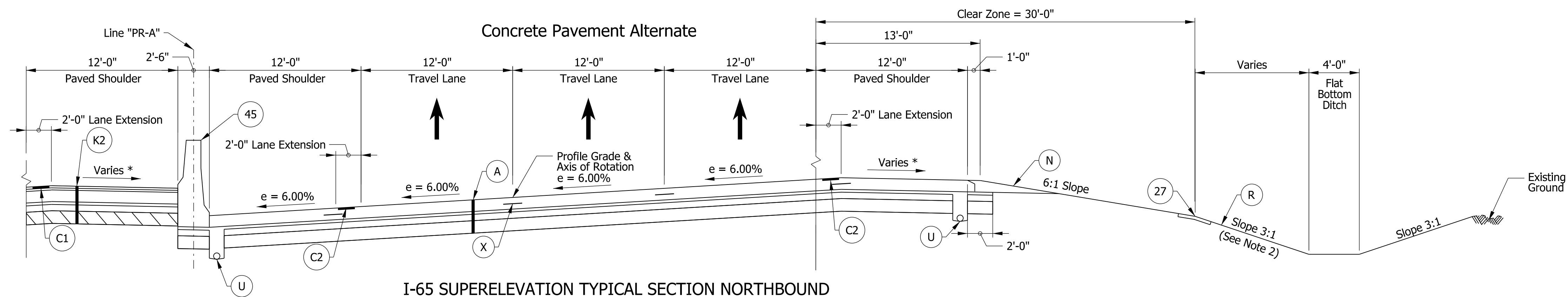

I-65 SUPERELEVATION TYPICAL SECTION NORTHBOUND
 A STA. 867+17.00 "PR-A" to STA. 903+41.00 "PR-A"

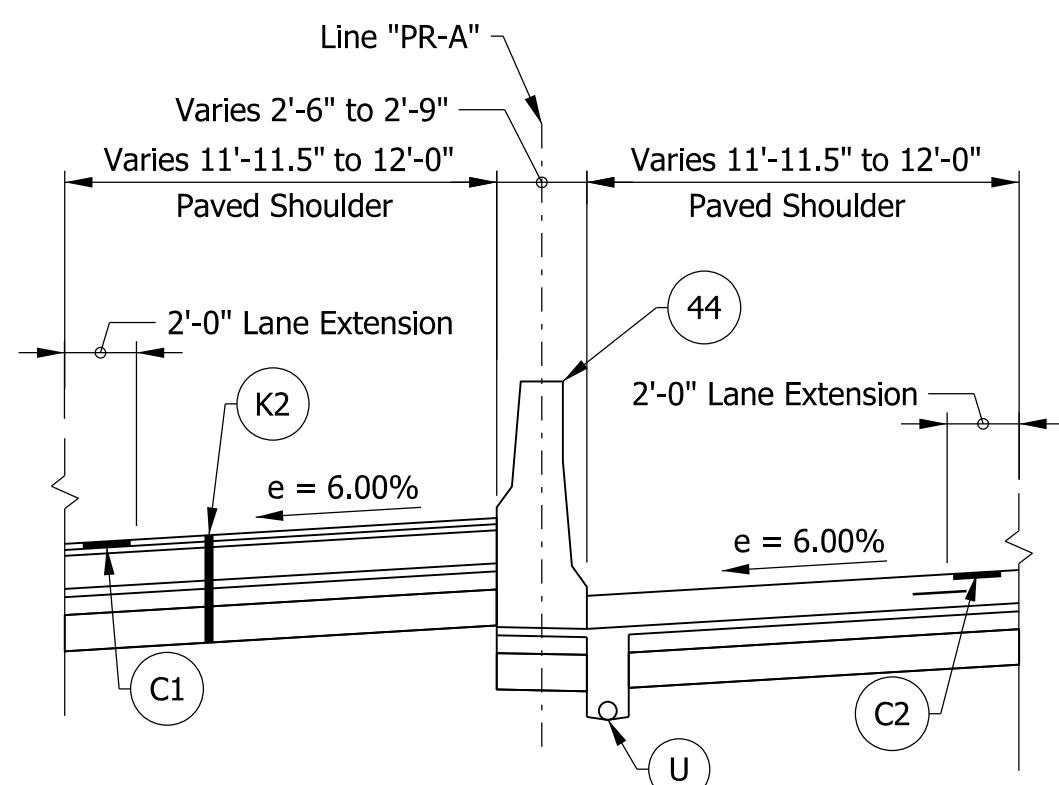

MODIFIED MEDIAN BARRIER DETAIL
 STA. 872+72.00 "PR-A" to STA. 873+02.00 "PR-A"
 STA. 878+98.00 "PR-A" to STA. 879+18.00 "PR-A"
 STA. 892+21.00 "PR-A" to STA. 892+41.00 "PR-A"
 STA. 894+57.00 "PR-A" to STA. 894+77.00 "PR-A"

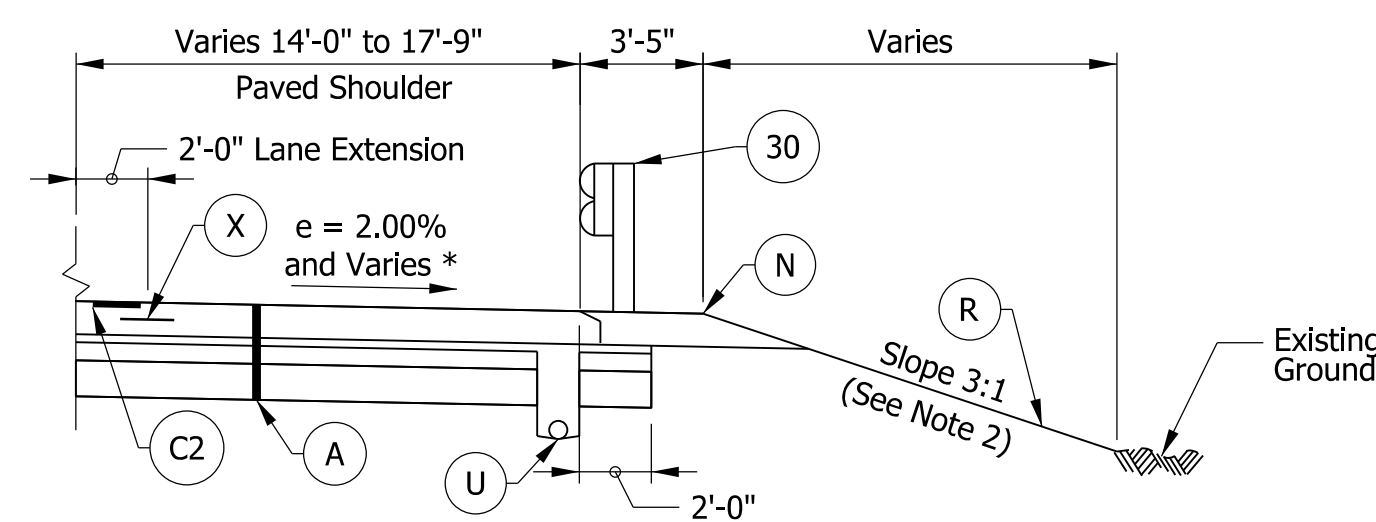

NB GUARDRAIL AND OUTSIDE SHOULDER DETAIL
 STA. 870+45.03 "PR-A" to STA. 873+83.59 "PR-A"
 STA. 888+73.84 "PR-A" to STA. 892+56.28 "PR-A"

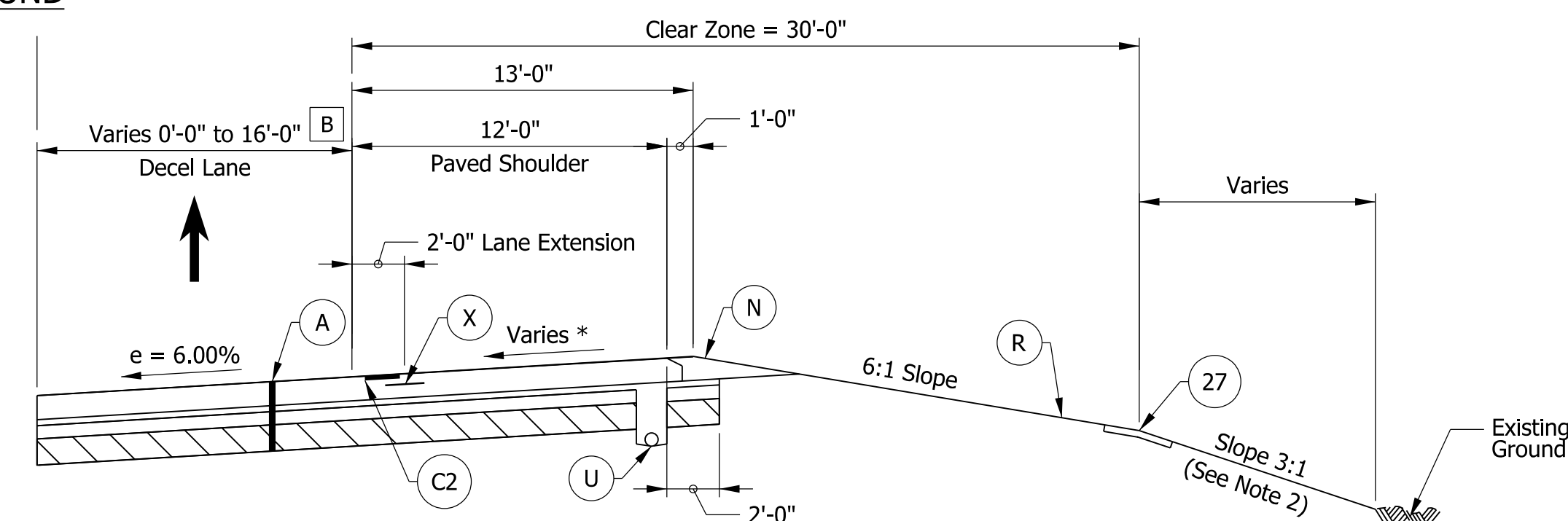

DECELERATION LANE - I-65 NORTHBOUND AT SR 43
 STA. 885+70.00 "PR-A" to STA. 892+07.73 "PR-A"

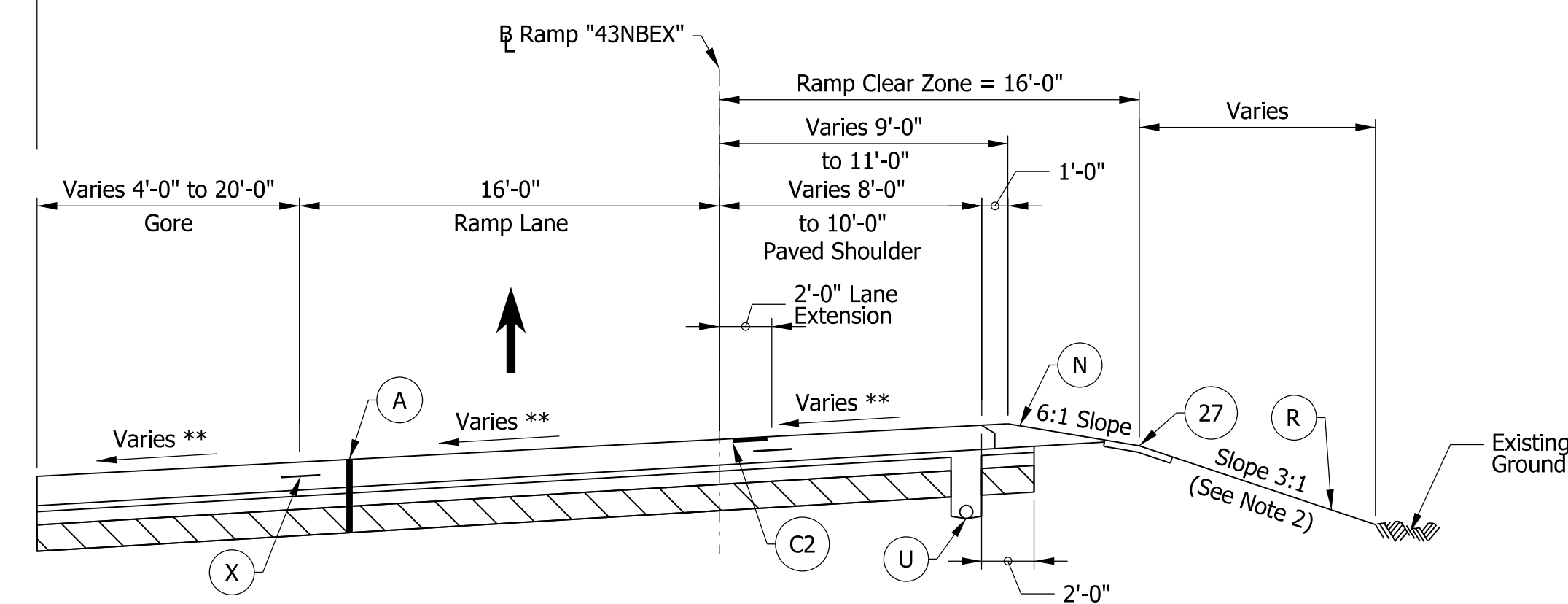

EXIT RAMP GORE SECTION - I-65 NORTHBOUND AT SR 43
 A STA. 892+07.73 "PR-A" to STA. 896+10.44 "PR-A"

- A NB Bridge Paving Exception from STA. 873+15.76 "PR-A" to STA. 878+87.58 "PR-A"
- NB Bridge Paving Exception from STA. 892+50.89 "PR-A" to STA. 894+26.50 "PR-A"
- B See Construction Detail sheets for limits of acceleration and deceleration lanes and taper limits.

Notes:

1. See DET-01 for Legend and Variable Width Table.
 2. See Cross Sections for varying slopes.
- * Max rollover between shoulder and travel lane not to exceed 8%. See Superelevation Detail for transition information
- ** Slope varies. See Gore Details.

NOTE TO REVIEWER:

Pavement design assumed to be asphalt for estimating purposes. Pavement design to be approved in a future submittal.

NOTE TO REVIEWER:

Safety Edge detail to be provided in a future submittal.

DRAFT
 NOT FOR CONSTRUCTION

RECOMMENDED FOR APPROVAL	DESIGN ENGINEER	DATE
DESIGNED: DCK	DRAWN: DCK	
CHECKED: MKM	CHECKED: MKM	

INDIANA
 DEPARTMENT OF TRANSPORTATION

TYPICAL CROSS SECTIONS
 I-65 LINE "PR-A"

HORIZONTAL SCALE	BRIDGE FILE
3/16"=1'-0"	N/A
VERTICAL SCALE	DESIGNATION
N/A	2001172 & 2100049
SURVEY BOOK	SHEETS
ELECTRONIC	6 of 536
CONTRACT	PROJECT
R-42909	2001172 & 2100049

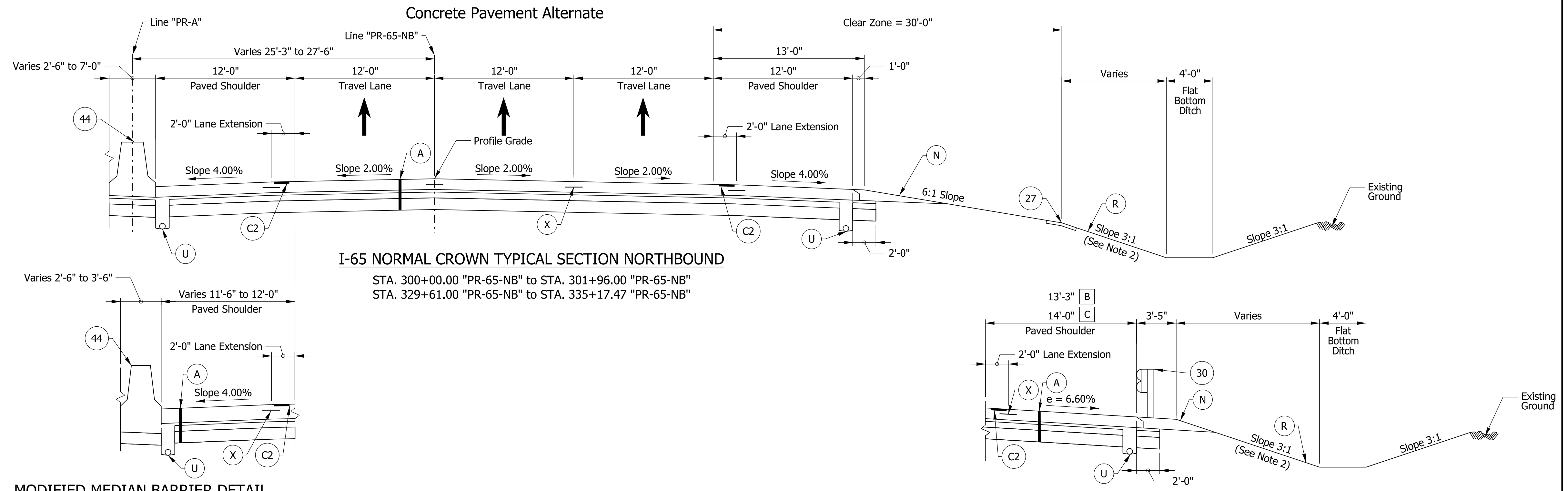

I-65 NORMAL CROWN TYPICAL SECTION NORTHBOUND
 STA. 300+00.00 "PR-65-NB" to STA. 301+96.00 "PR-65-NB"
 STA. 329+61.00 "PR-65-NB" to STA. 335+17.47 "PR-65-NB"

MODIFIED MEDIAN BARRIER DETAIL
 STA. 300+67.00 "PR-65-NB" to STA. 301+53.00 "PR-65-NB"

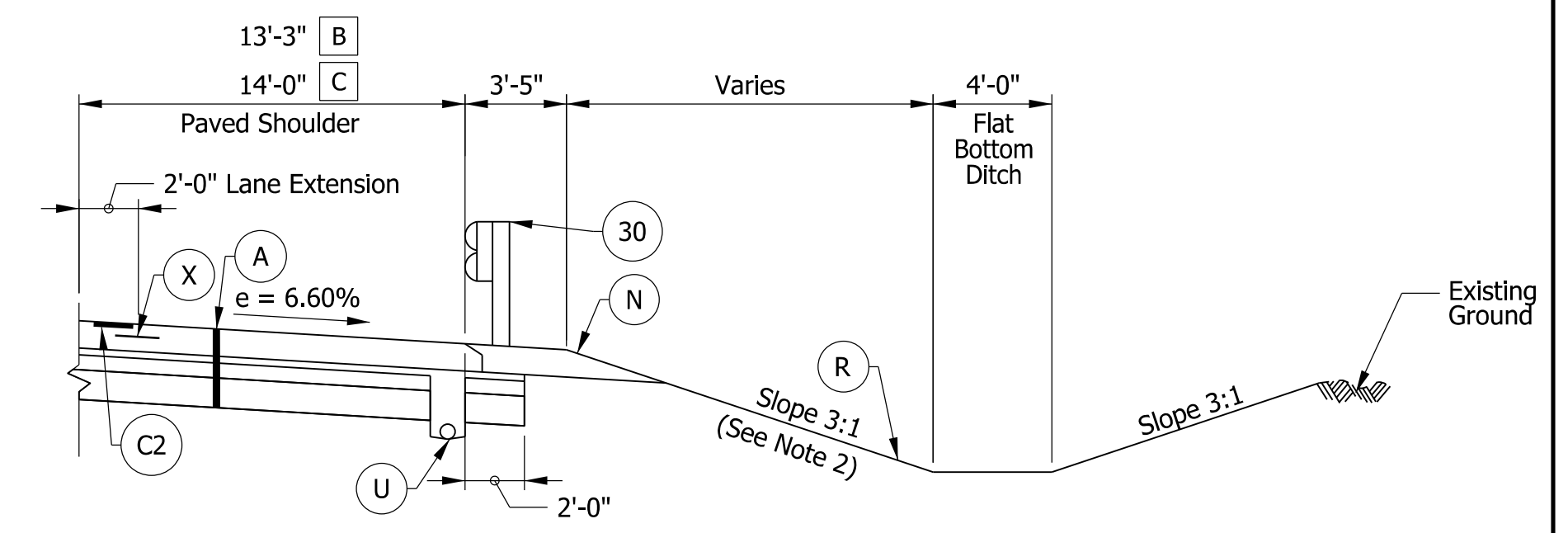

NB GUARDRAIL AND OUTSIDE SHOULDER DETAIL
 STA. 305+58.04 "PR-65-NB" to STA. 308+13.45 "PR-65-NB" B
 STA. 316+92.06 "PR-65-NB" to STA. 322+36.79 "PR-65-NB" C

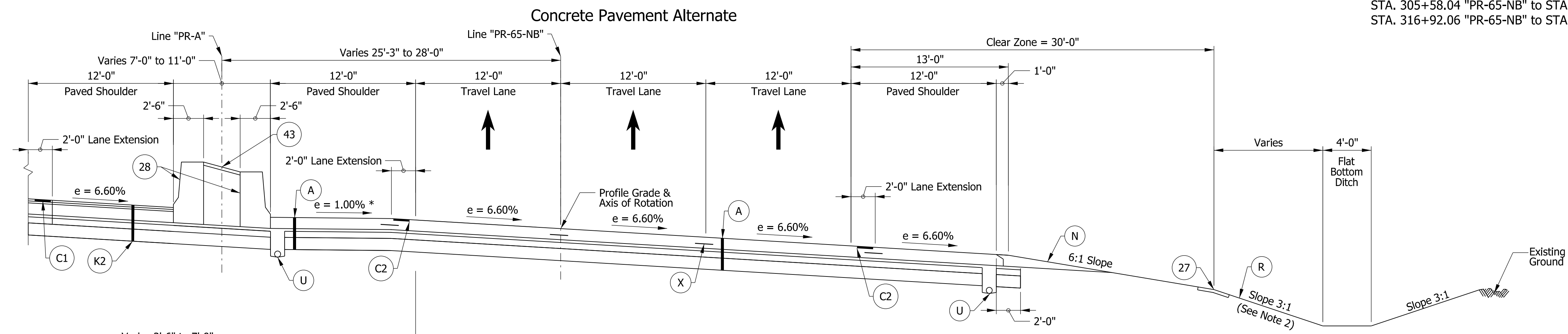

I-65 SUPERELEVATION TYPICAL SECTION NORTHBOUND
 A STA. 301+96.00 "PR-65-NB" to STA. 329+61.00 "PR-65-NB"

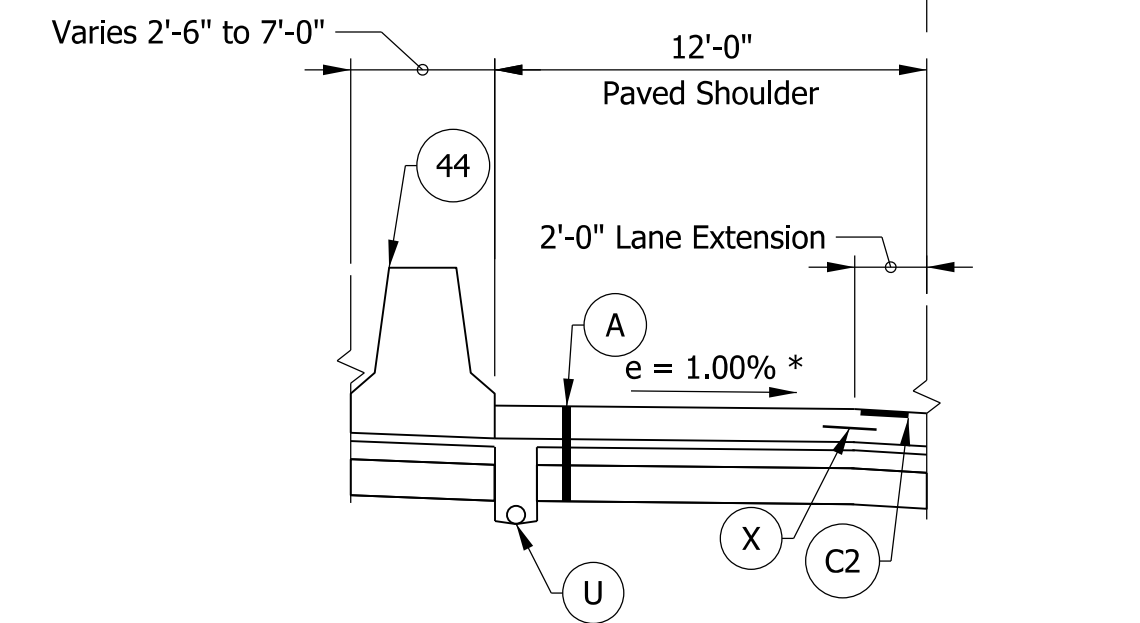

MODIFIED MEDIAN BARRIER DETAIL
 STA. 301+96.00 "PR-65-NB" to STA. 305+20.20 "PR-65-NB"
 STA. 326+08.07 "PR-65-NB" to STA. 329+61.00 "PR-65-NB"

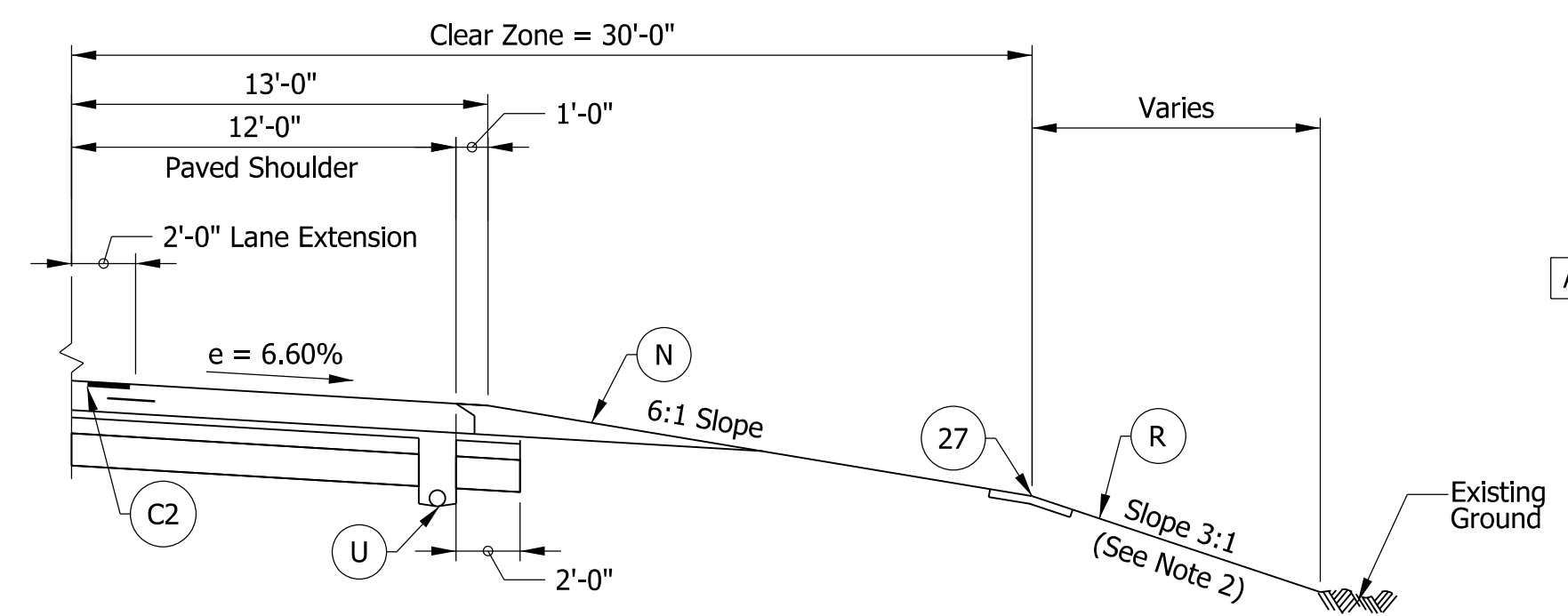

NB OUTSIDE SHOULDER DETAIL
 STA. 308+13.45 "PR-65-NB" to STA. 314+00.00 "PR-65-NB"

A NB Bridge Paving Exception from STA. 308+13.45 "PR-65-NB" to STA. 309+93.48 "PR-65-NB"

- Notes:**
- See DET-01 for Legend and Variable Width Table.
 - Cross slope varies. See Cross Sections for varying slopes. See Superelevation Detail and Intersection Detail Sheets for cross slope transition locations.
 - Proposed improvements to follow "PR-65-NB" and "PR-65-SB" between STA. 940+10.00 "PR-A" and STA. 975+45.00 "PR-A".
- * Max rollover between shoulder and travel lane not to exceed 8%. See Superelevation Detail for transition information

NOTE TO REVIEWER:
 Pavement design assumed to be asphalt for estimating purposes. Pavement design to be approved in a future submittal.

NOTE TO REVIEWER:
 Safety Edge detail to be provided in a future submittal.

DRAFT
 NOT FOR CONSTRUCTION

RECOMMENDED FOR APPROVAL _____	DESIGN ENGINEER _____	DATE _____
DESIGNED: _____ DCK _____	DRAWN: _____ DCK _____	
CHECKED: _____ MKM _____	CHECKED: _____ MKM _____	

INDIANA
 DEPARTMENT OF TRANSPORTATION

TYPICAL CROSS SECTIONS
 I-65 LINE "PR-65-NB"

HORIZONTAL SCALE	BRIDGE FILE
3/16"=1'-0"	N/A
VERTICAL SCALE	DESIGNATION
N/A	2001172 & 2100049
SURVEY BOOK	SHEETS
ELECTRONIC	7 of 536
CONTRACT	PROJECT
R-42909	2001172 & 2100049

rstriegel
 1/20/2021 10:46:36 am
 model:Sheet7
 file:c:\candib\pwr\striegel\pwr\great_lakes\02\40385\2001172-rd-s-hyp01.dgn

rstrnegel
 1/20/2021 10:46:37 am
 model: Sheet8
 file: c:\candib\pwr\strnegel\pwr\great_lakes\024038512001172-rd-s-hyrd01.dgn

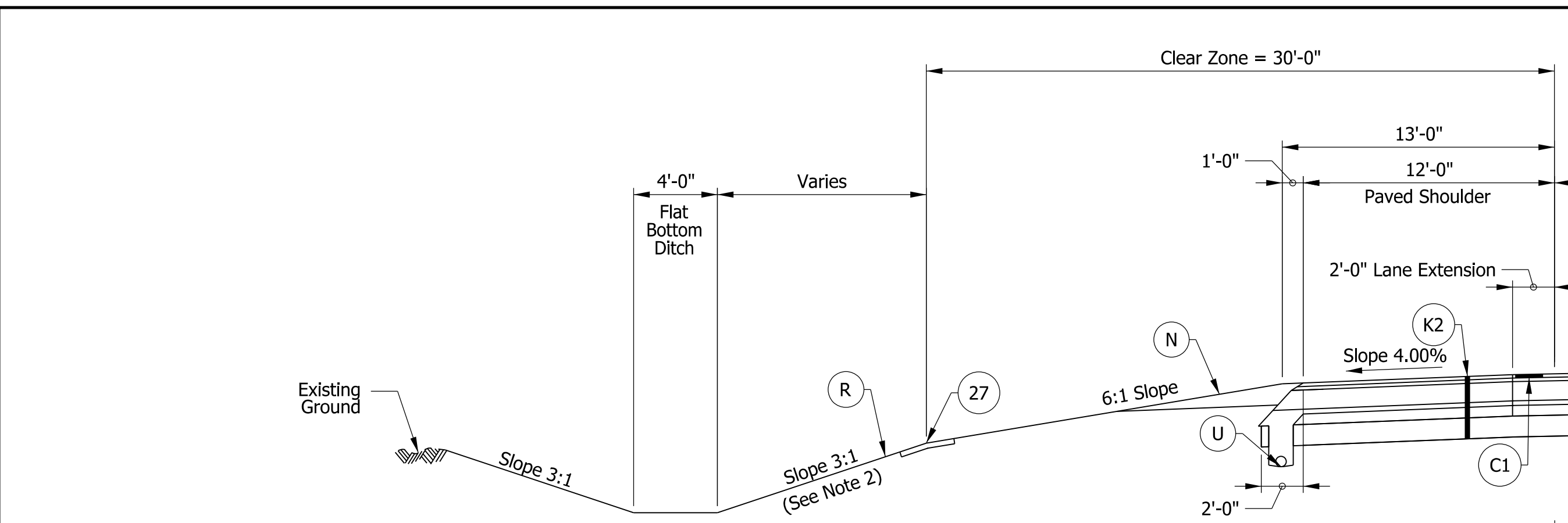

I-65 NORMAL CROWN TYPICAL SECTION SOUTHBOUND

A STA. 828+21.00 "PR-A" to STA. 867+17.00 "PR-A"
 STA. 902+85.00 "PR-A" to STA. 940+10.00 "PR-A"
 STA. 975+40.00 "PR-A" to STA. 1029+20.00 "PR-A"

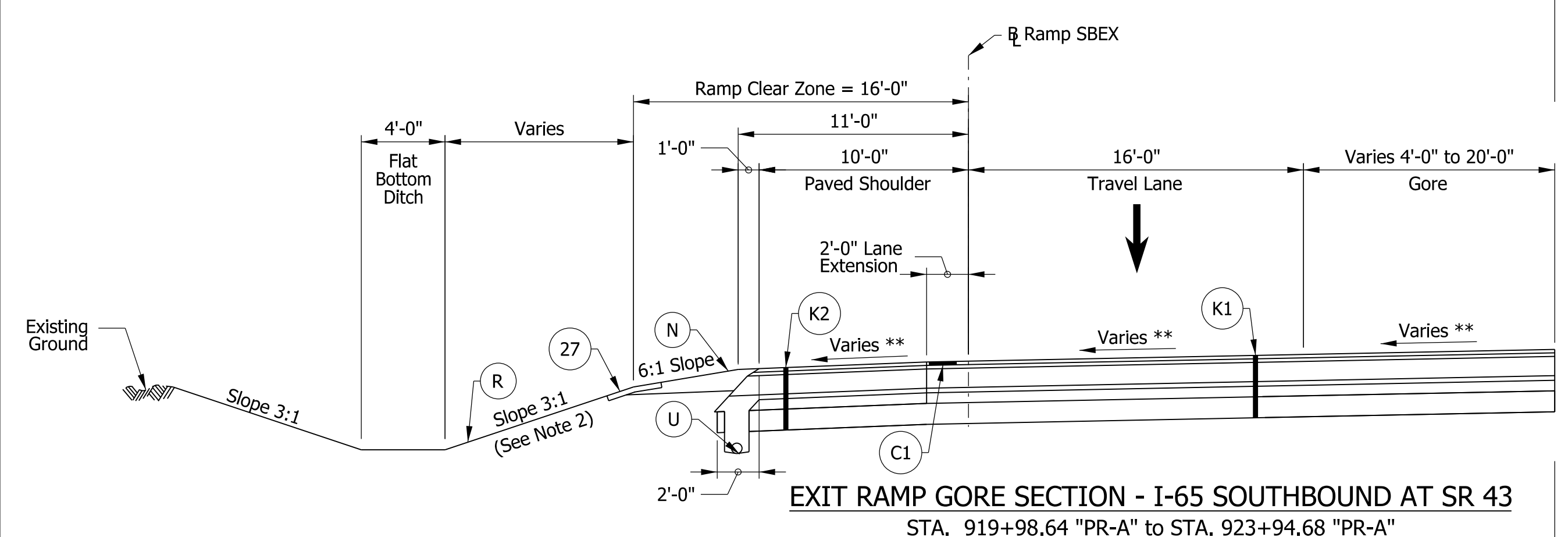

EXIT RAMP GORE SECTION - I-65 SOUTHBOUND AT SR 43
 STA. 919+98.64 "PR-A" to STA. 923+94.68 "PR-A"

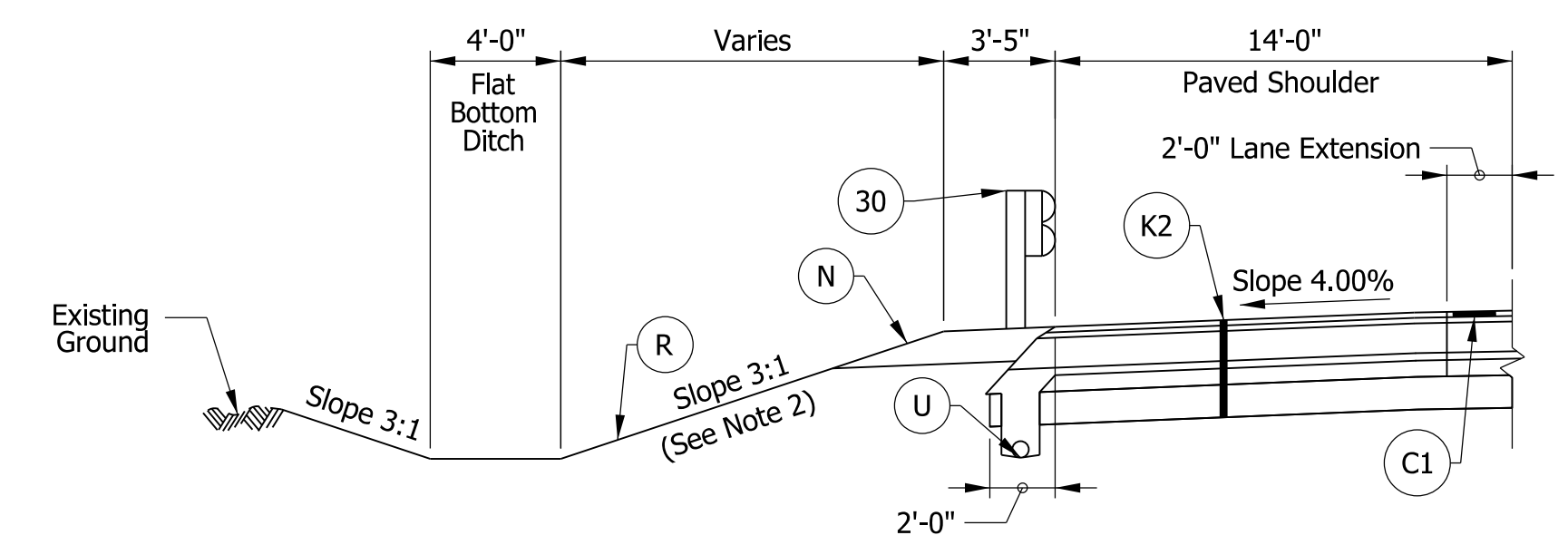

SB GUARDRAIL AND OUTSIDE SHOULDER DETAIL

STA. 856+40.25 "PR-A" to STA. 859+34.00 "PR-A" SB
 STA. 906+72.23 "PR-A" to STA. 909+14.68 "PR-A" SB
 STA. 925+73.42 "PR-A" to STA. 927+10.92 "PR-A" SB

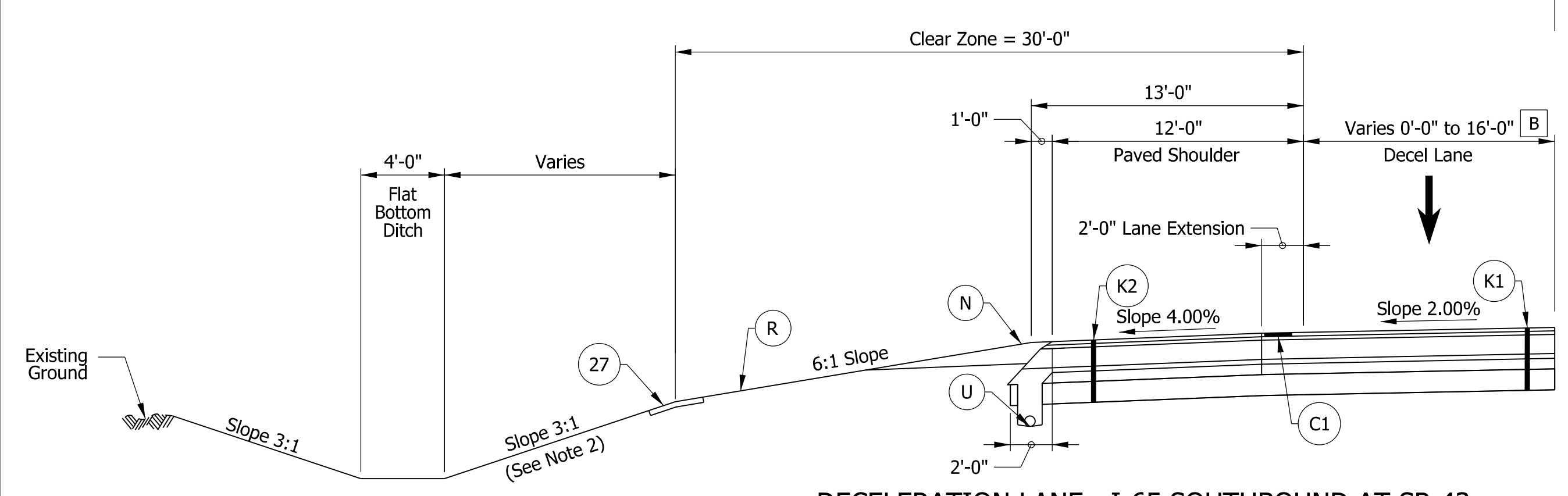

DECELERATION LANE - I-65 SOUTHBOUND AT SR 43
 STA. 923+94.68 "PR-A" to STA. 932+95.00 "PR-A"

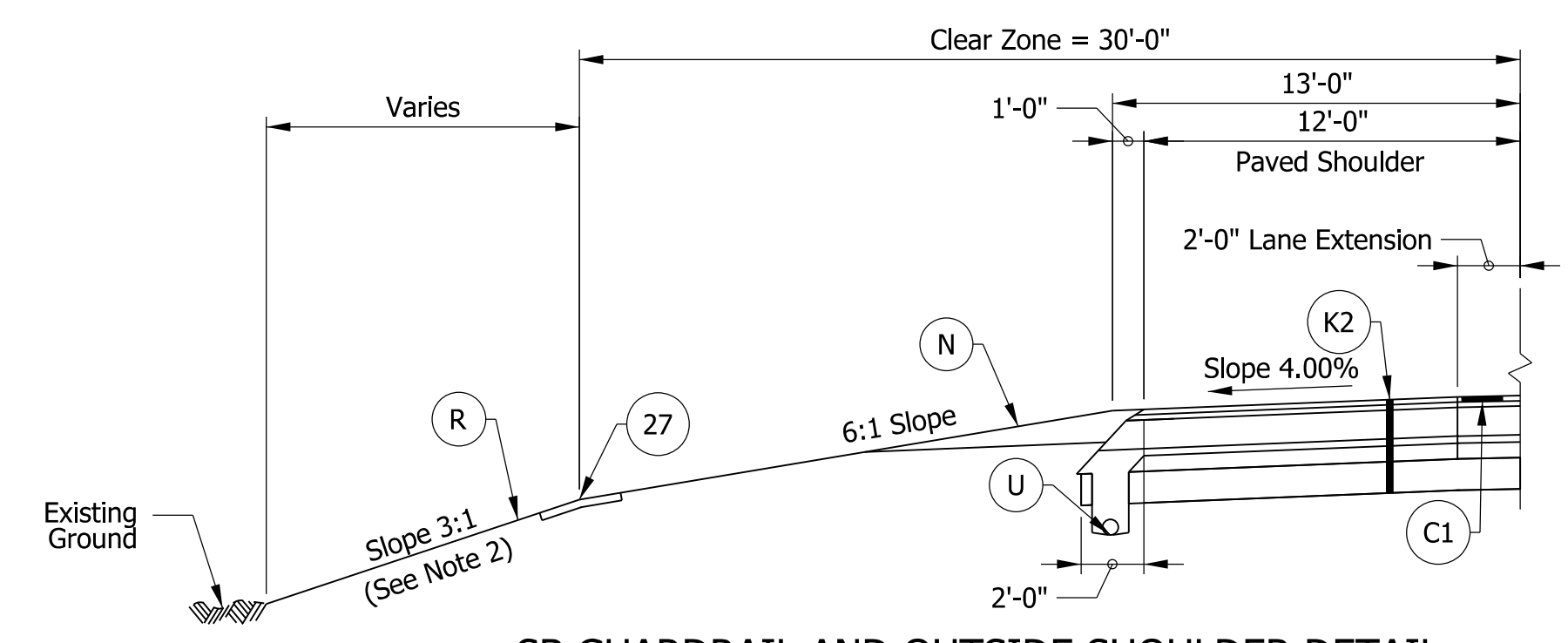

SB GUARDRAIL AND OUTSIDE SHOULDER DETAIL

STA. 828+21.00 "PR-A" to STA. 833+50.00 "PR-A" SB
 STA. 861+00.00 "PR-A" to STA. 867+17.00 "PR-A" SB
 STA. 911+00.00 "PR-A" to STA. 917+00.00 "PR-A" SB
 STA. 936+00.00 "PR-A" to STA. 938+50.00 "PR-A" SB
 STA. 989+00.00 "PR-A" to STA. 1013+00.00 "PR-A" SB

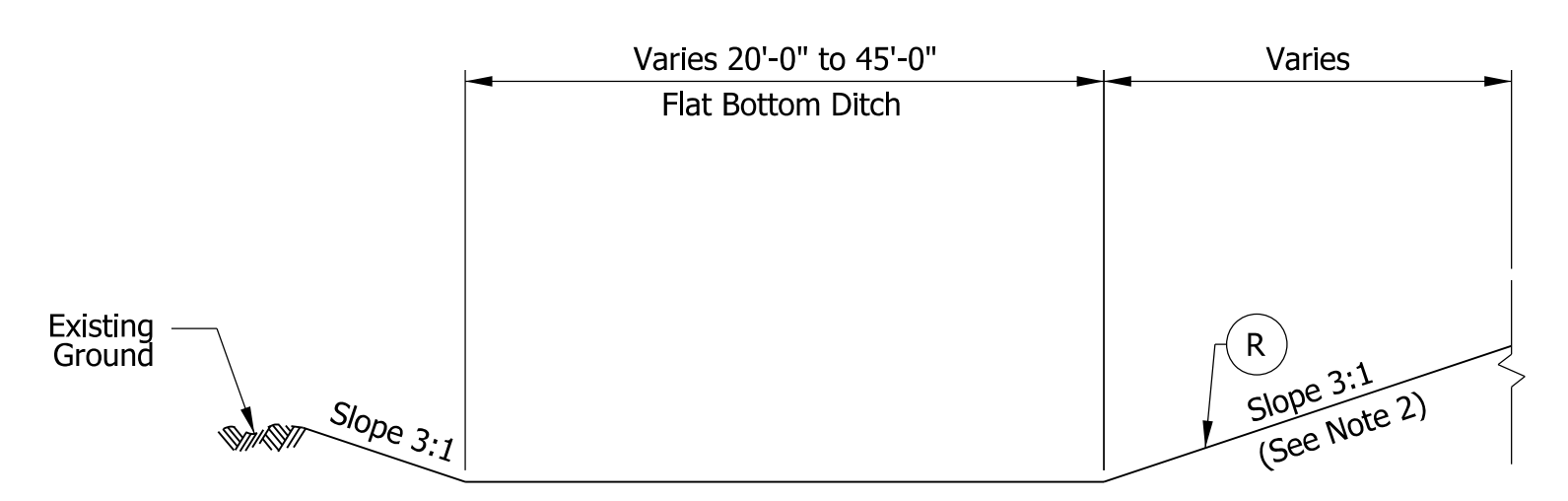

OUTSIDE WIDE DITCH DETAIL
 STA. 835+00.00 "PR-A" to STA. 839+50.00 "PR-A" SB

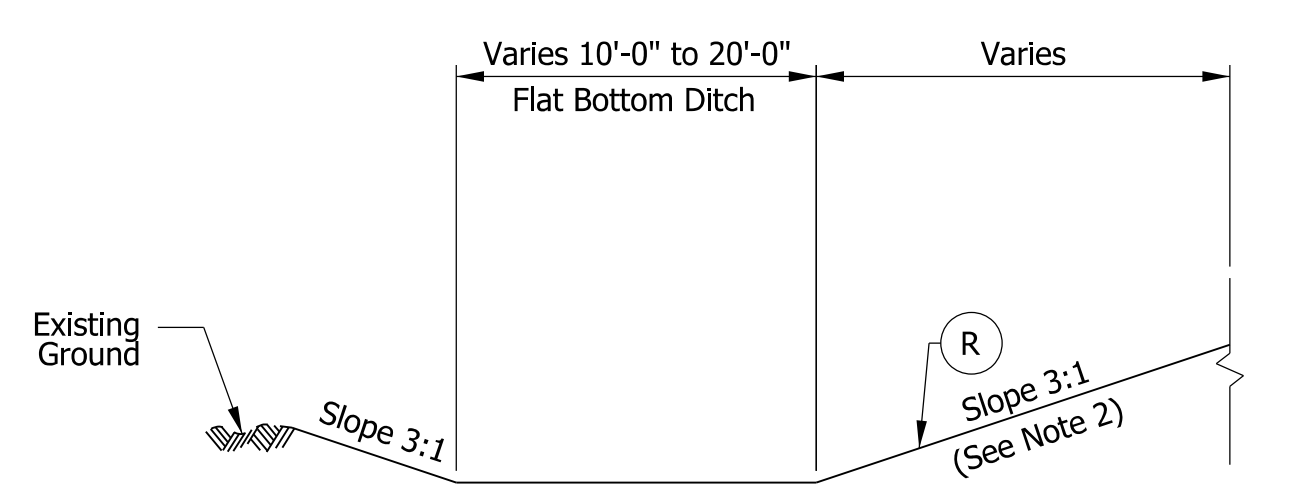

OUTSIDE WIDE DITCH DETAIL
 STA. 839+50.00 "PR-A" to STA. 840+50.00 "PR-A" SB
 STA. 846+00.00 "PR-A" to STA. 855+50.00 "PR-A" SB

- A SB Bridge Paving Exception from STA. 904+98.17 "PR-A" to STA. 907+09.70 "PR-A"
- B See Construction Detail sheets for limits of acceleration and deceleration lanes and taper limits.

- Notes:**
- See DET-01 for Legend and Variable Width Table.
 - Cross slope varies. See Cross Sections for varying slopes. See Superelevation Detail and Intersection Detail Sheets for cross slope transition locations.
 - Proposed improvements to follow "PR-65-NB" and "PR-65-SB" between STA. 940+10.00 "PR-A" and STA. 975+45.00 "PR-A".
- * Max rollover between shoulder and travel lane not to exceed 8%. See Superelevation Detail for transition information
- ** Slope varies. See Gore Details.

NOTE TO REVIEWER:
 Pavement design assumed to be asphalt for estimating purposes. Pavement design to be approved in a future submittal.

NOTE TO REVIEWER:
 Safety Edge detail to be provided in a future submittal.

DRAFT
 NOT FOR CONSTRUCTION

RECOMMENDED FOR APPROVAL	DESIGN ENGINEER	DATE
DESIGNED: DCK	DRAWN: DCK	
CHECKED: MKM	CHECKED: MKM	

INDIANA DEPARTMENT OF TRANSPORTATION
TYPICAL CROSS SECTIONS
I-65 LINE "PR-A"

HORIZONTAL SCALE	BRIDGE FILE
3/16"=1'-0"	N/A
VERTICAL SCALE	DESIGNATION
N/A	2001172 & 2100049
SURVEY BOOK	SHEETS
ELECTRONIC	8 of 536
CONTRACT	PROJECT
R-42909	2001172 & 2100049

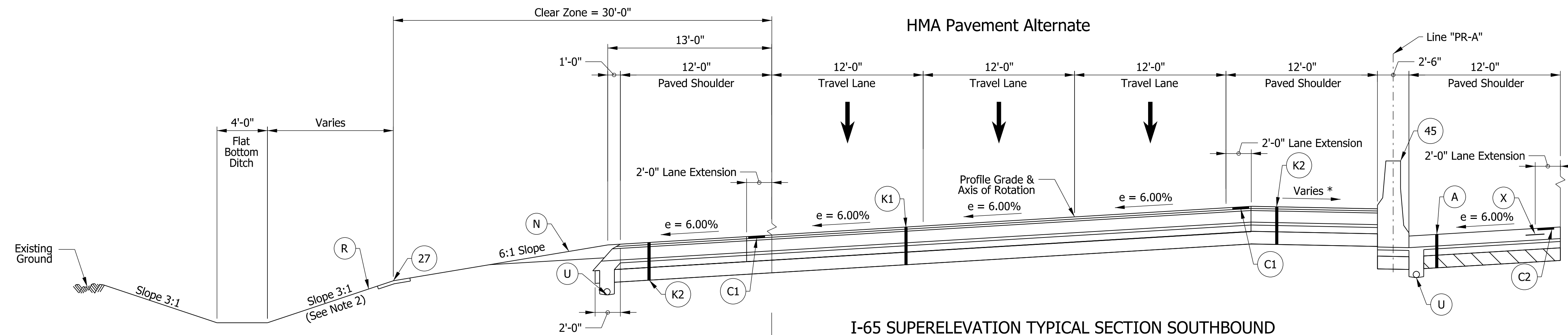

I-65 SUPERELEVATION TYPICAL SECTION SOUTHBOUND

A STA. 867+17.00 "PR-A" to STA. 903+41.00 "PR-A"

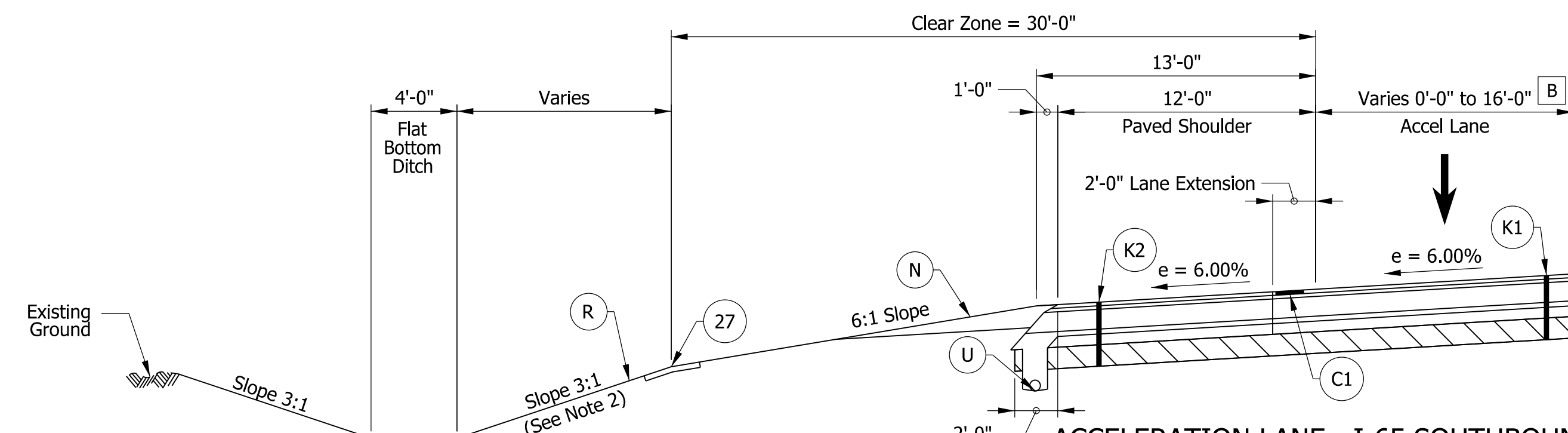

ACCELERATION LANE - I-65 SOUTHBOUND AT SR 43

A STA. 879+14.50 "PR-A" to STA. 895+94.65 "PR-A"

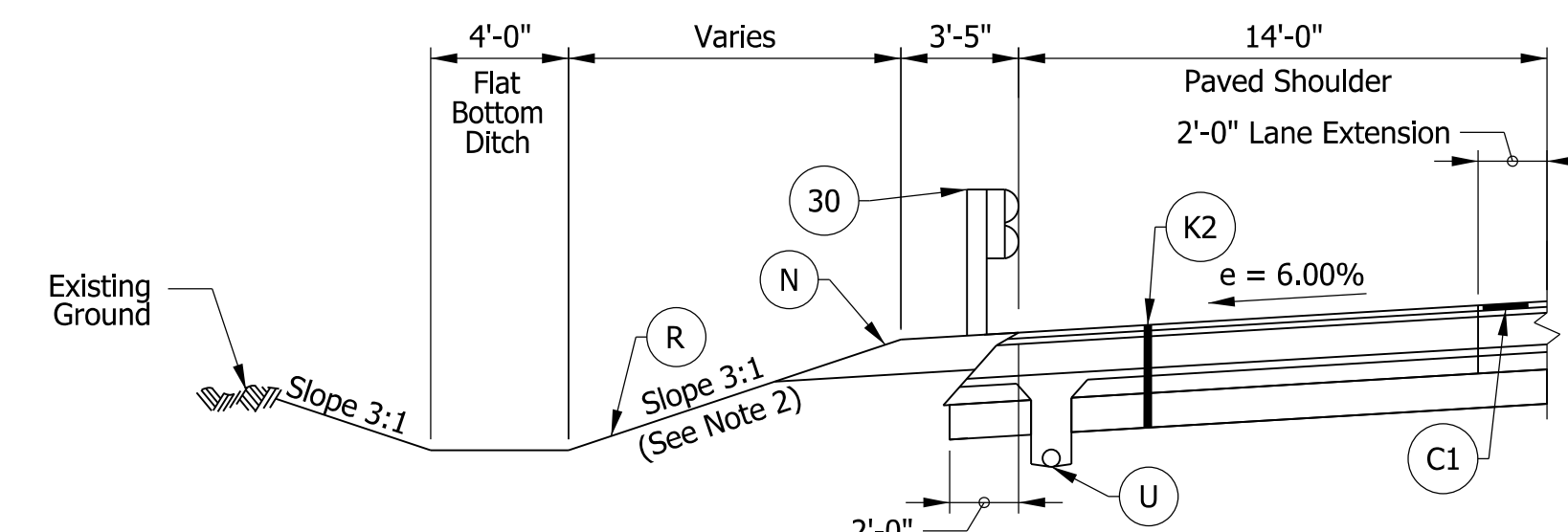

SB GUARDRAIL AND OUTSIDE SHOULDER DETAIL

A STA. 878+57.77 "PR-A" to STA. 881+31.48 "PR-A"
 STA. 894+43.88 "PR-A" to STA. 896+40.77 "PR-A"

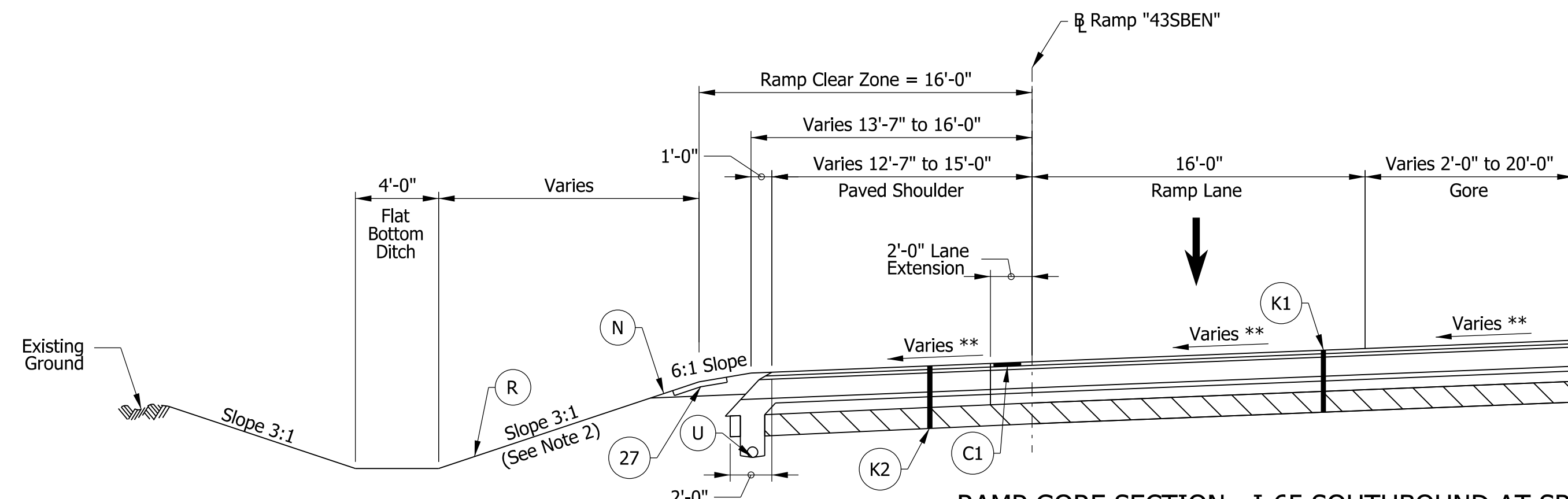

RAMP GORE SECTION - I-65 SOUTHBOUND AT SR 43

STA. 895+94.65 "PR-A" to STA. 896+87.97 "PR-A"

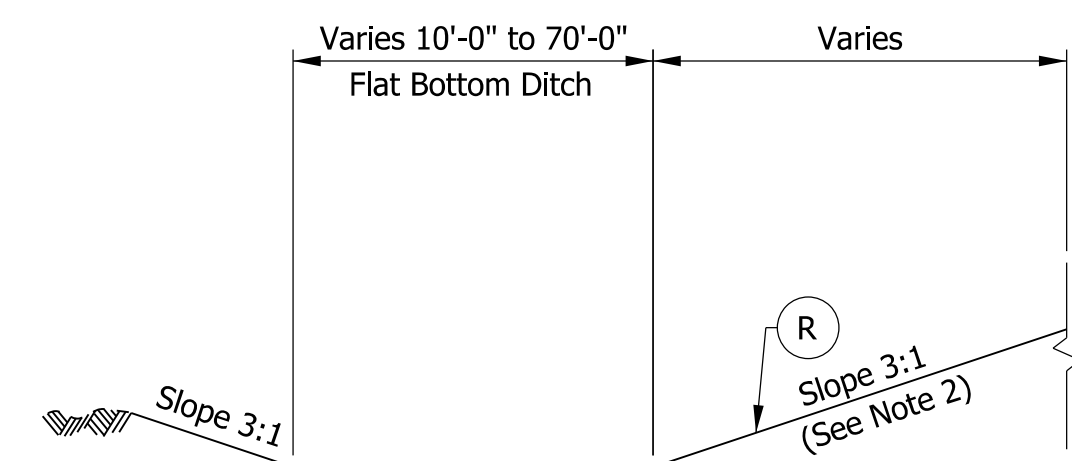

OUTSIDE WIDE DITCH DETAIL

STA. 885+50.00 "PR-A" to STA. 891+00.00 "PR-A" SB

- A SB Bridge Paving Exception from STA. 872+72.35 "PR-A" to STA. 878+76.30 "PR-A"
- SB Bridge Paving Exception from STA. 892+70.14 "PR-A" to STA. 894+49.55 "PR-A"
- B See Construction Detail sheets for limits of acceleration and deceleration lanes and taper limits.

Notes:

1. See DET-01 for Legend and Variable Width Table.
 2. Cross slope varies. See Cross Sections for varying slopes. See Superelevation Detail and Intersection Detail Sheets for cross slope transition locations.
 3. Proposed improvements to follow "PR-65-NB" and "PR-65-SB" between STA. 940+10.00 "PR-A" and STA. 975+45.00 "PR-A".
- * Max rollover between shoulder and travel lane not to exceed 8%. See Superelevation Detail for transition information
- ** Slope varies. See Gore Details.

NOTE TO REVIEWER:

Pavement design assumed to be asphalt for estimating purposes. Pavement design to be approved in a future submittal.

NOTE TO REVIEWER:

Safety Edge detail to be provided in a future submittal.

DRAFT
NOT FOR CONSTRUCTION

RECOMMENDED FOR APPROVAL _____	DESIGN ENGINEER _____	DATE _____
DESIGNED: _____ DCK _____	DRAWN: _____ DCK _____	
CHECKED: _____ MKM _____	CHECKED: _____ MKM _____	

INDIANA
DEPARTMENT OF TRANSPORTATION

TYPICAL CROSS SECTIONS
I-65 LINE "PR-A"

HORIZONTAL SCALE	BRIDGE FILE
3/16"=1'-0"	N/A
VERTICAL SCALE	DESIGNATION
N/A	2001172 & 2100049
SURVEY BOOK	SHEETS
ELECTRONIC	9 of 536
CONTRACT	PROJECT
R-42909	2001172 & 2100049

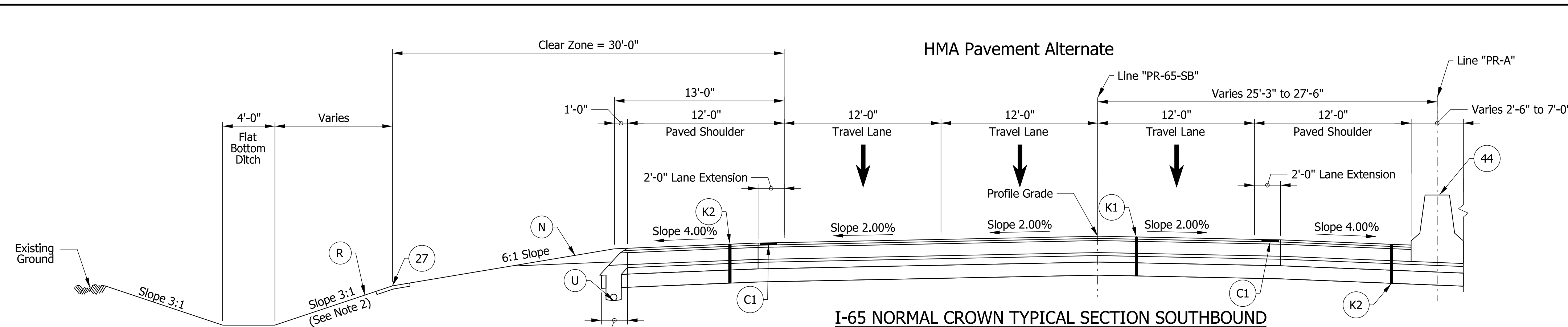

I-65 NORMAL CROWN TYPICAL SECTION SOUTHBOUND
 STA. 200+00.00 "PR-65-SB" to STA. 201+72.00 "PR-65-SB"
 STA. 230+34.00 "PR-65-SB" to STA. 235+54.50 "PR-65-SB"

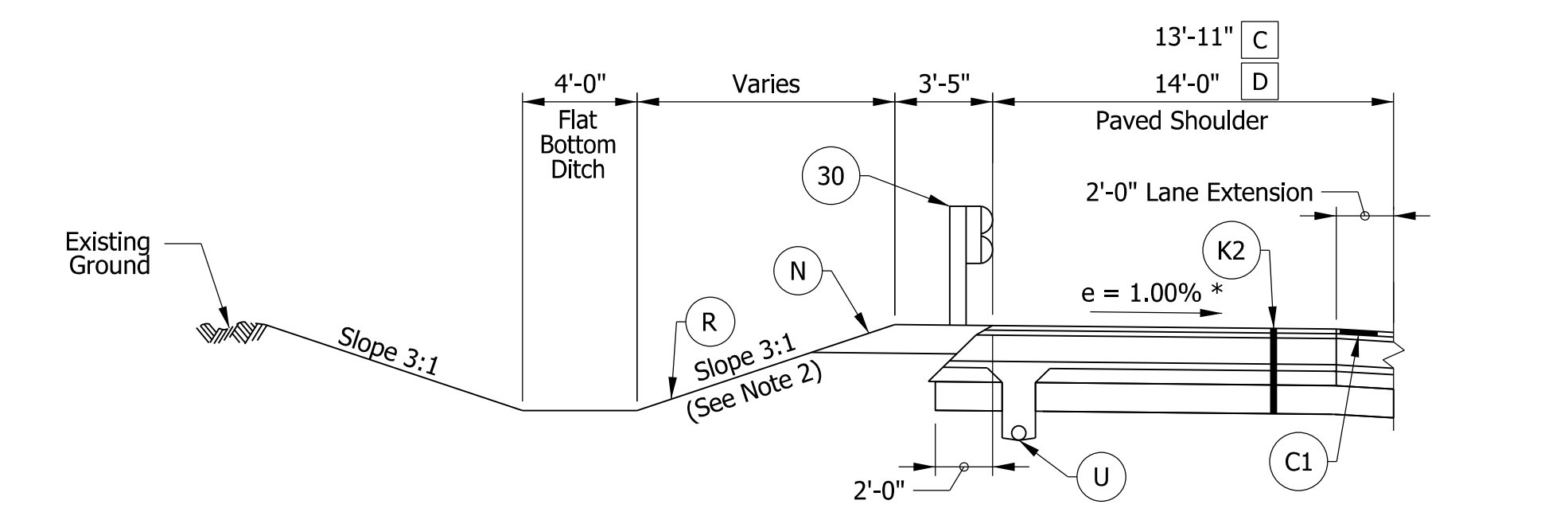

SB GUARDRAIL AND OUTSIDE SHOULDER DETAIL
 STA. 209+94.56 "PR-65-SB" to STA. 212+46.24 "PR-65-SB"
 STA. 222+96.24 "PR-65-SB" to STA. 227+05.00 "PR-65-SB"

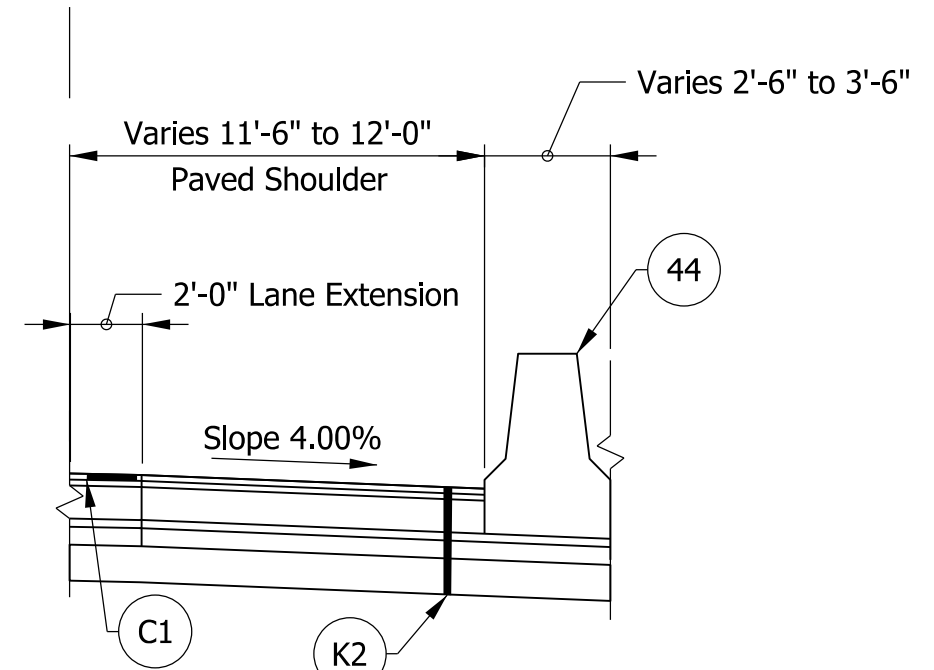

MODIFIED MEDIAN BARRIER DETAIL
 STA. 200+66.85 "PR-65-SB" to STA. 201+52.86 "PR-65-SB"

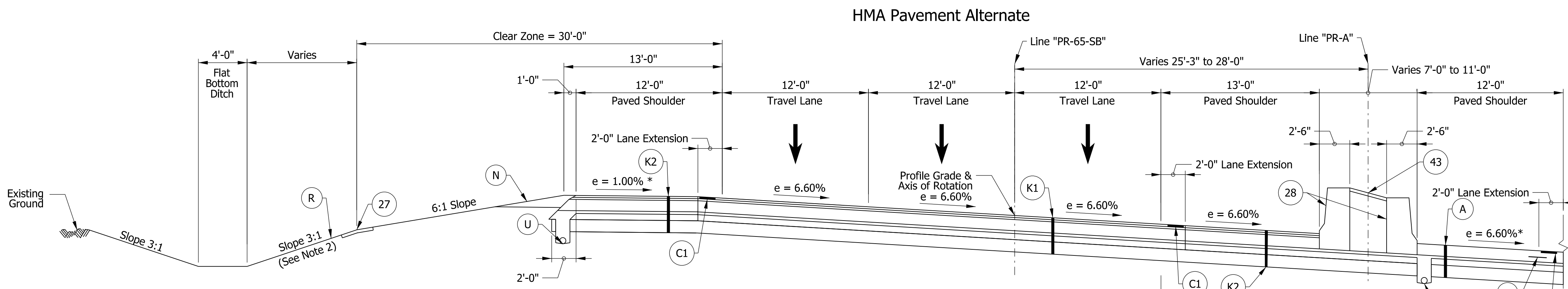

I-65 SUPERELEVATION TYPICAL SECTION SOUTHBOUND
 STA. 201+72.00 "PR-65-SB" to STA. 230+34.00 "PR-65-SB"

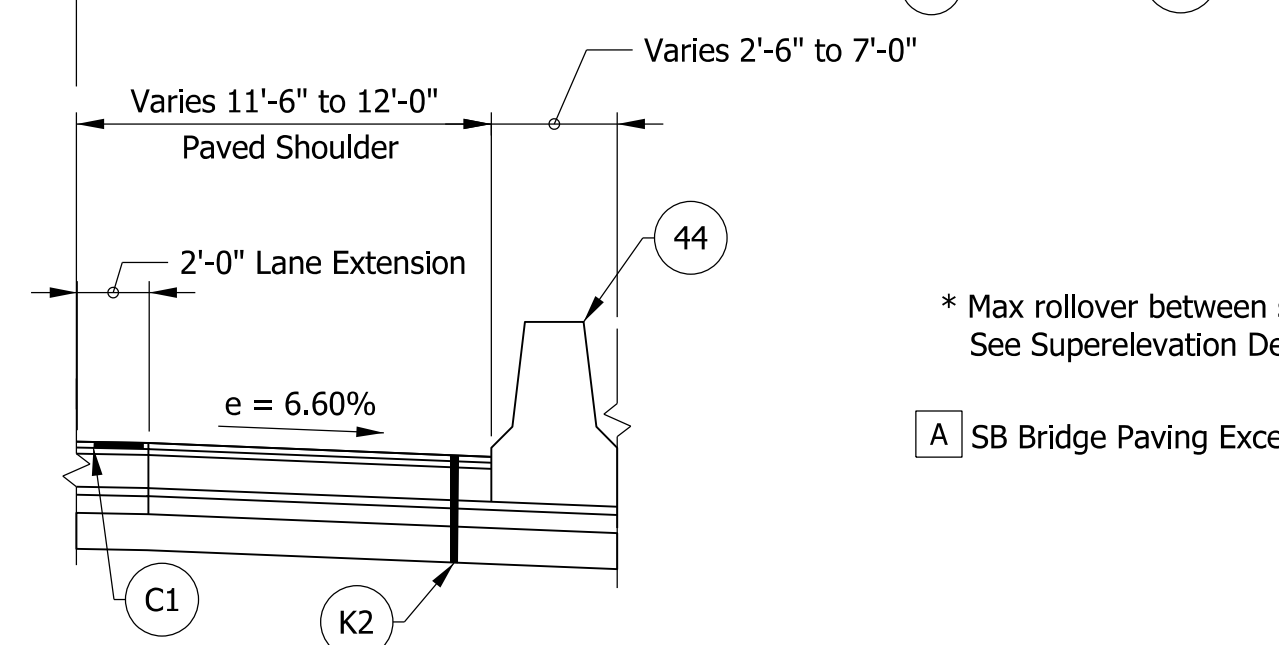

MODIFIED MEDIAN BARRIER DETAIL
 STA. 201+72.00 "PR-65-SB" to STA. 205+20.04 "PR-65-SB"
 STA. 226+45.19 "PR-65-SB" to STA. 230+34.00 "PR-65-SB"

* Max rollover between shoulder and travel lane not to exceed 8%.
 See Superelevation Detail for transition information

A SB Bridge Paving Exception from STA. 208+18.63 "PR-65-SB" to STA. 209+98.66 "PR-65-SB"

- Notes:**
- See DET-01 for Legend and Variable Width Table.
 - Cross slope varies. See Cross Sections for varying slopes. See Superelevation Detail and Intersection Detail Sheets for cross slope transition locations.
 - Proposed improvements to follow "PR-65-NB" and "PR-65-SB" between STA. 940+10.00 "PR-A" and STA. 975+45.00 "PR-A".

NOTE TO REVIEWER:
 Pavement design assumed to be asphalt for estimating purposes. Pavement design to be approved in a future submittal.

NOTE TO REVIEWER:
 Safety Edge detail to be provided in a future submittal.

NOTE TO REVIEWER:
 High side shoulder along southbound travel lanes in superelevations to remain at 1% towards roadway to match proposed design of DES. NO. 1601091.

DRAFT
 NOT FOR CONSTRUCTION

RECOMMENDED FOR APPROVAL	DESIGN ENGINEER	DATE
DESIGNED: DCK	DRAWN: DCK	
CHECKED: MKM	CHECKED: MKM	

INDIANA
 DEPARTMENT OF TRANSPORTATION

TYPICAL CROSS SECTIONS
 LINE "PR-65-SB"

HORIZONTAL SCALE	BRIDGE FILE
3/16"=1'-0"	N/A
VERTICAL SCALE	DESIGNATION
N/A	2001172 & 2100049
SURVEY BOOK	SHEETS
ELECTRONIC	10 of 536
CONTRACT	PROJECT
R-42909	2001172 & 2100049

rstriegel
 1/20/2021 10:46:39 am
 model:Sheet10
 file:c:\candib\pwr\rstriegel\pwr\great_lakes\02-40385\2001172-rd-s-hyp01.dgn

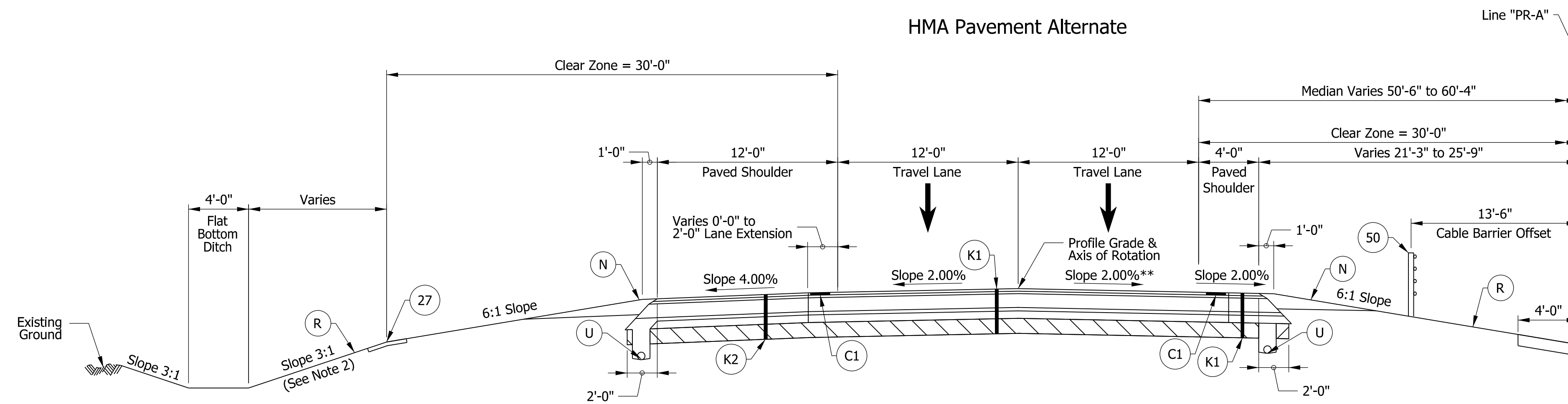

I-65 NORMAL CROWN TYPICAL SECTION SOUTHBOUND
 STA. 1029+20.00 "PR-A" to STA. 1036+03.00 "PR-A"

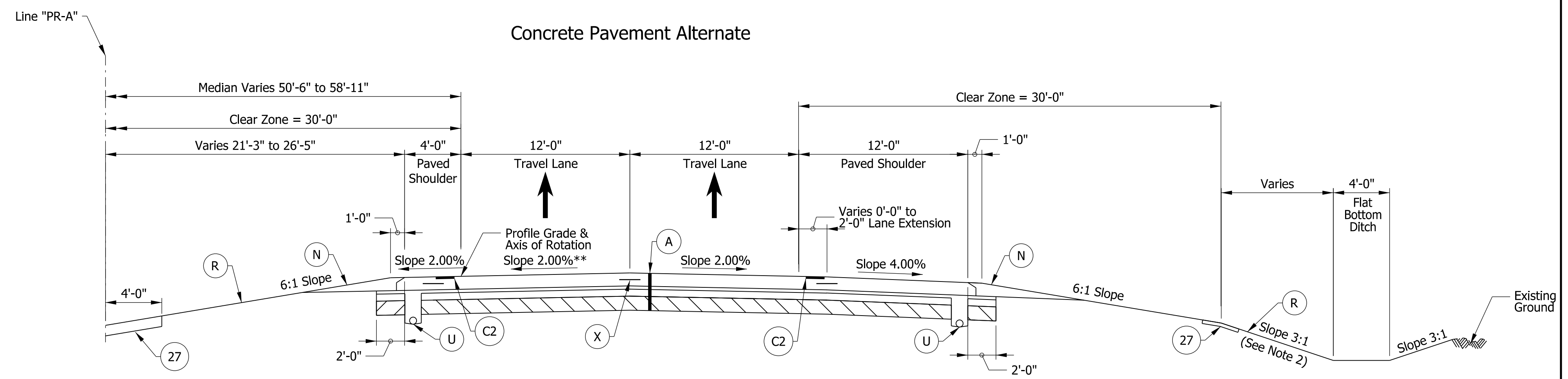

I-65 NORMAL CROWN TYPICAL SECTION NORTHBOUND
 STA. 1029+20.00 "PR-A" to STA. 1034+90.00 "PR-A"

- Notes:**
- See DET-01 for Legend and Variable Width Table.
 - See Cross Sections for varying slopes.
- ** Slope varies. Slope transition from STA. 1029+20.00 "PR-A" to STA. 1031+00.00 "PR-A"
 See Superelevation Details for transition information.

NOTE TO REVIEWER:
 Pavement design assumed to be asphalt for estimating purposes. Pavement design to be approved in a future submittal.

NOTE TO REVIEWER:
 Safety Edge detail to be provided in a future submittal.

DRAFT
 NOT FOR CONSTRUCTION

RECOMMENDED FOR APPROVAL _____	DESIGN ENGINEER _____	DATE _____
DESIGNED: _____ DCK _____	DRAWN: _____ DCK _____	
CHECKED: _____ MKM _____	CHECKED: _____ MKM _____	

INDIANA
 DEPARTMENT OF TRANSPORTATION

TYPICAL CROSS SECTIONS
 I-65 LINE "PR-A"

HORIZONTAL SCALE	BRIDGE FILE
3/16"=1'-0"	N/A
VERTICAL SCALE	DESIGNATION
N/A	2001172 & 2100049
SURVEY BOOK	SHEETS
ELECTRONIC	11 of 536
CONTRACT	PROJECT
R-42909	2001172 & 2100049

rstriegel
 1/20/2021 10:46:39 am
 model:Sheet11
 file:c:\caddib\pwr\rstriegel\pwr\grat_lakes\02403851\2001172-rf-s-hyp01.dgn

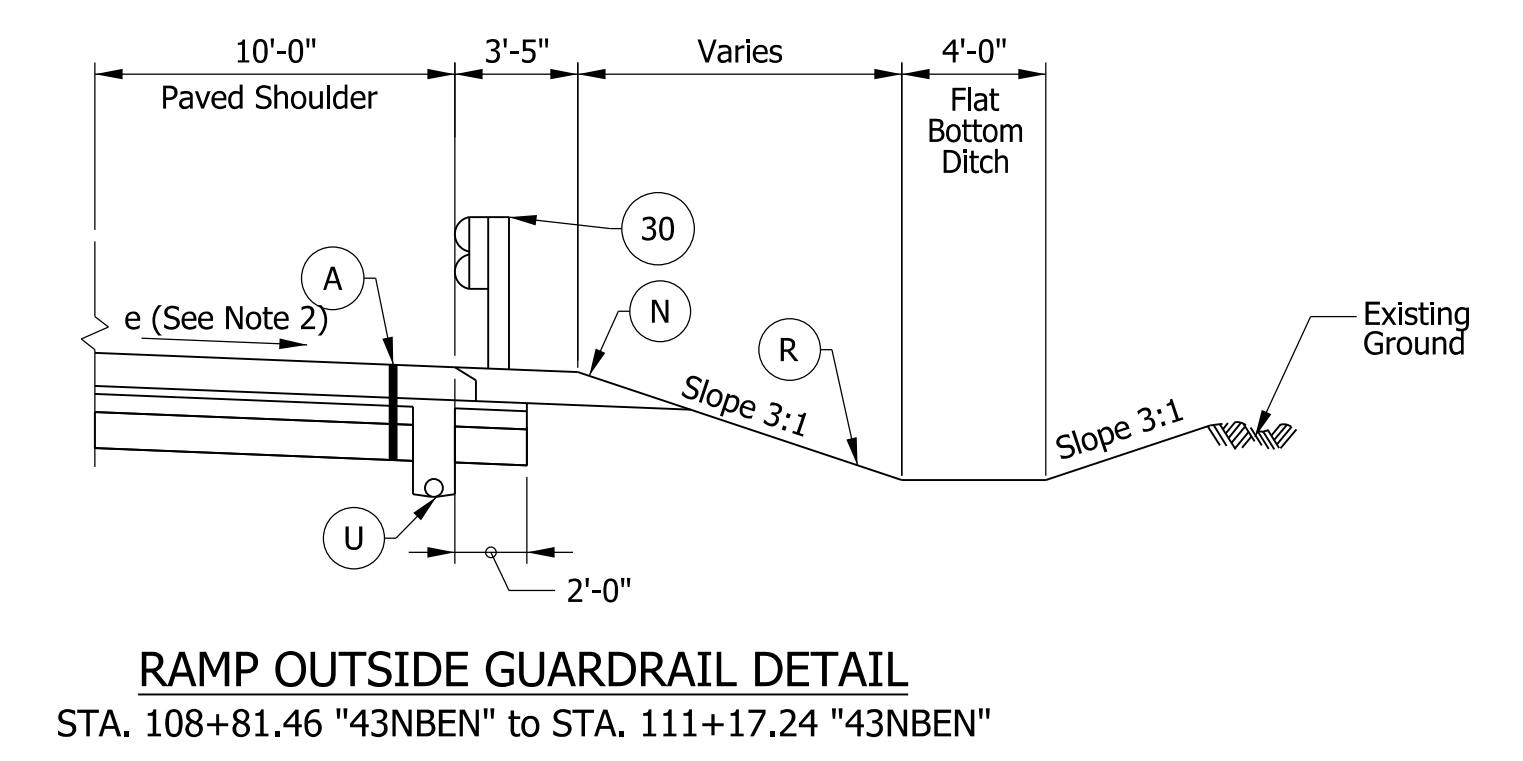
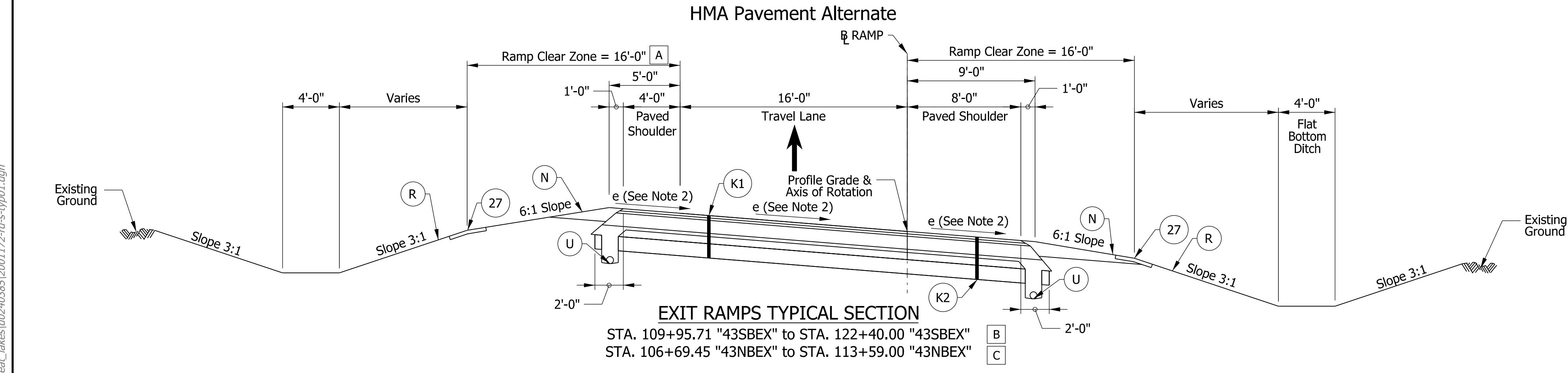
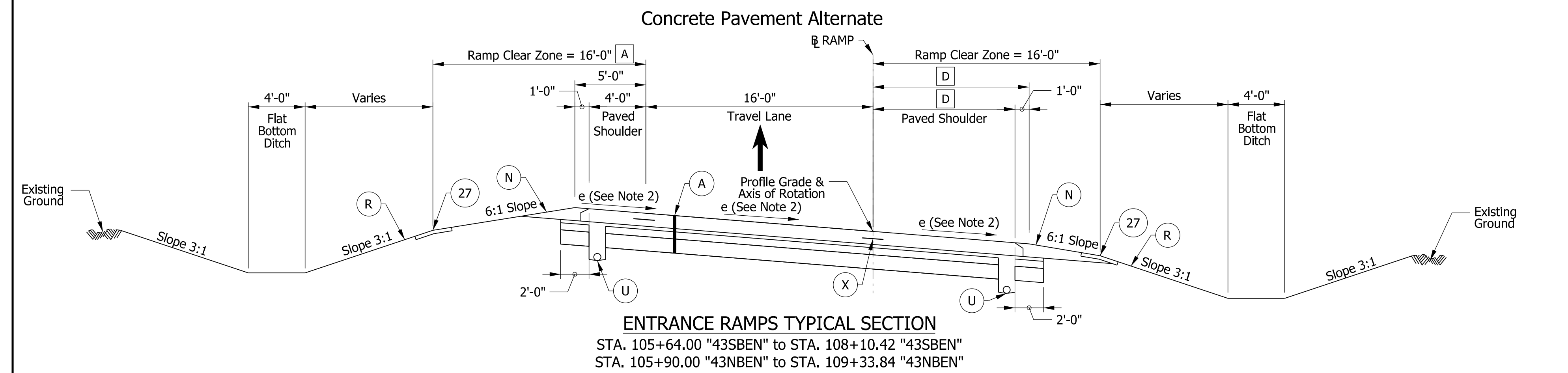
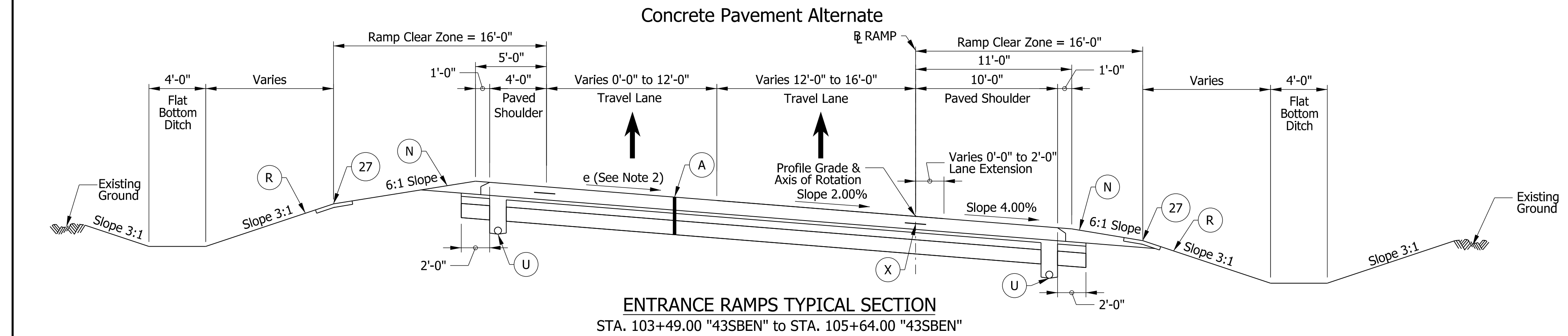
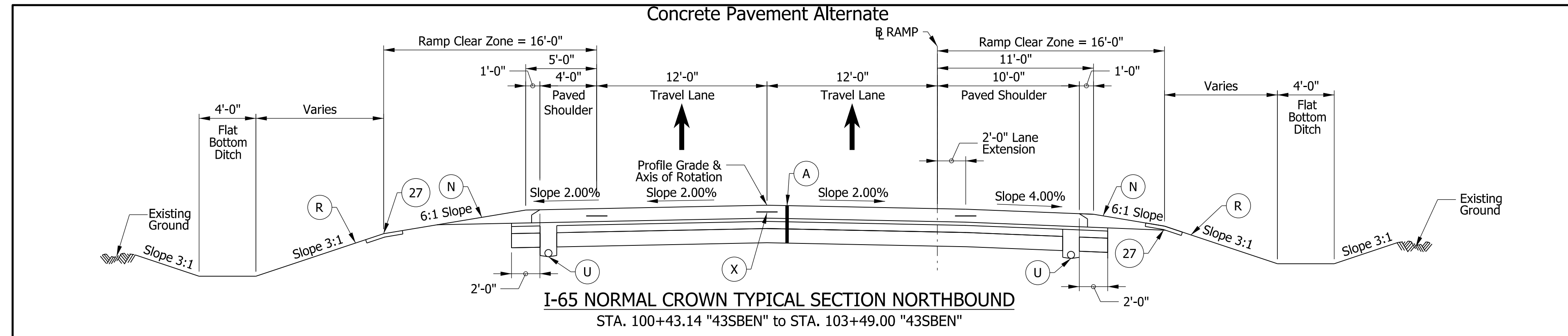

- Notes:**
- A Clear zone width varies. See Variable Width Table.
 - B SBEX backslope varies from 3:1 to 6:1 from STA. 109+95.71 "43SBEX" to STA. 121+25.95 "43SBEX"
 - C See Construction details for NBEX Ramp backslope and ditch bottom revetment.
 - D Paved Shoulder width = 8'-0"; Usable Shoulder width = 9'-0" for "43NBEN"
Paved Shoulder width = 10'-0"; Usable Shoulder width = 11'-0" for "43SBEN" See Variable Width Table.
- Notes:**
1. See DET-01 for Legend and Variable Width Table.
 2. Cross slope varies. See Superelevation Detail and Intersection Detail Sheets for cross slope transition locations.

NOTE TO REVIEWER:
Pavement design assumed to be asphalt for estimating purposes. Pavement design to be approved in a future submittal.

NOTE TO REVIEWER:
Safety Edge detail to be provided in a future submittal.

DRAFT
NOT FOR CONSTRUCTION

RECOMMENDED FOR APPROVAL _____	DESIGN ENGINEER _____	DATE _____
DESIGNED: _____ DCK _____	DRAWN: _____ DCK _____	
CHECKED: _____ MKM _____	CHECKED: _____ MKM _____	

INDIANA DEPARTMENT OF TRANSPORTATION

TYPICAL CROSS SECTIONS SR 43 RAMPS

HORIZONTAL SCALE	BRIDGE FILE
3/16"=1'-0"	N/A
VERTICAL SCALE	DESIGNATION
N/A	2001172 & 2100049
SURVEY BOOK	SHEETS
ELECTRONIC	12 of 536
CONTRACT	PROJECT
R-42909	2001172 & 2100049

rstrnegel
1/20/2021 10:46:40 am
model:Sheet12
file:c:\candlib\pwr\strnegel\pwr\great_lakes\02\40385\2001172-rf-s-hyp01.dgn

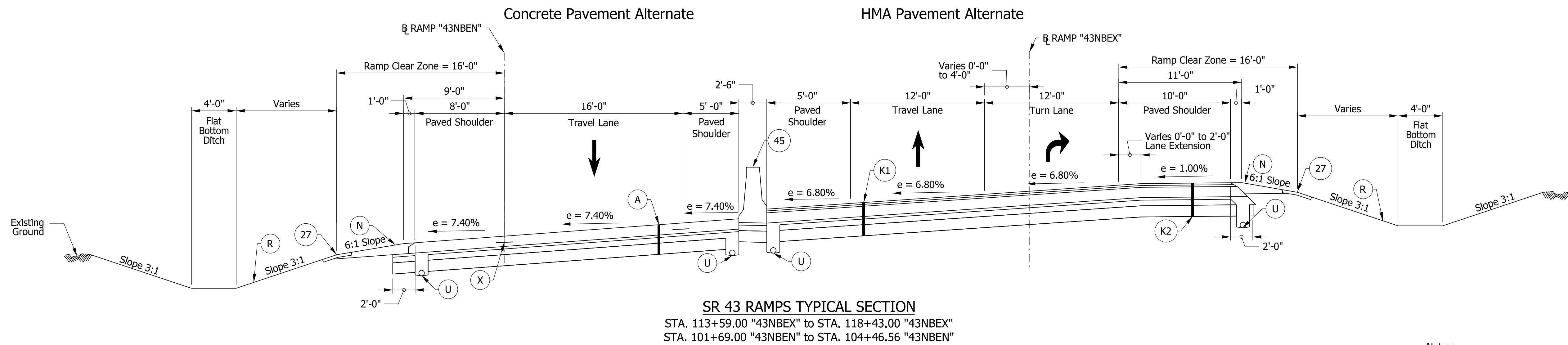
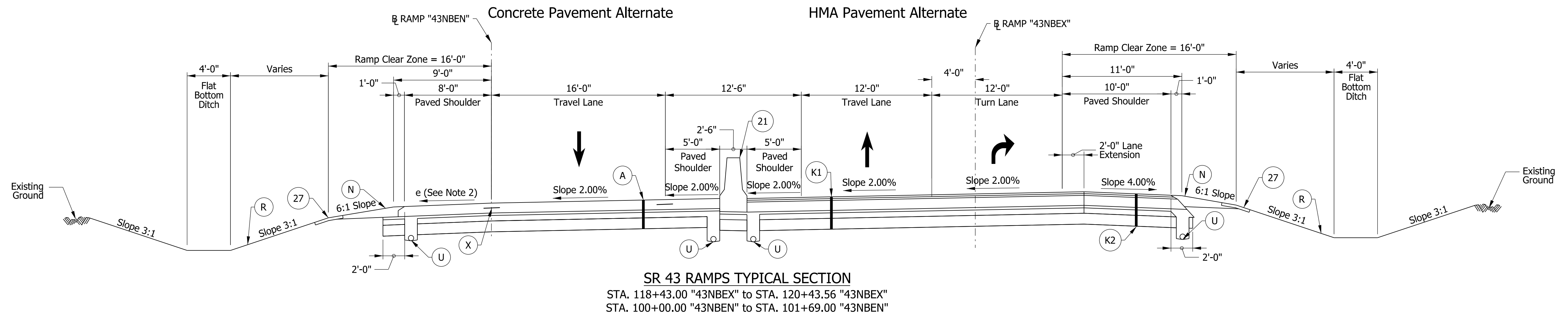
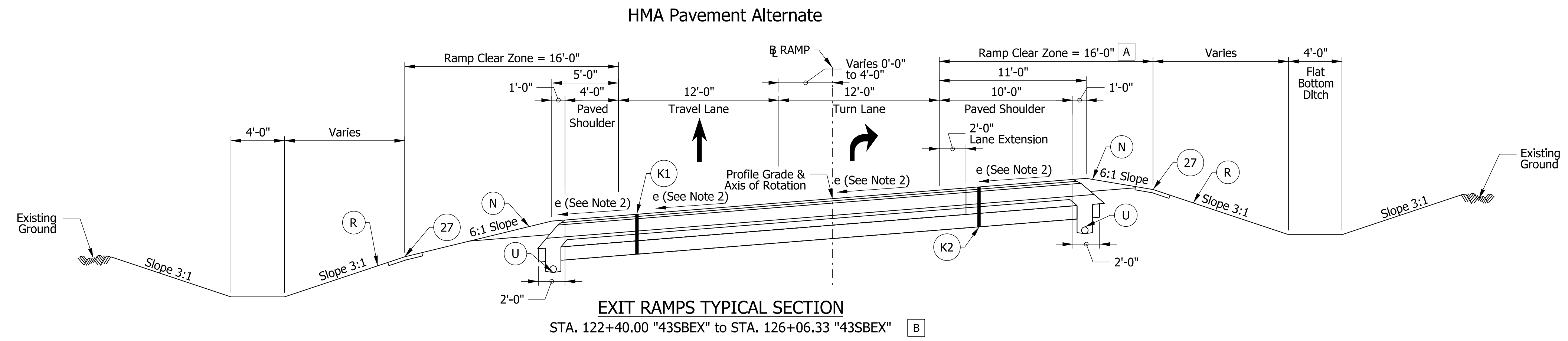

[A] Clear zone width varies. See Variable Width Table.

[B] SBEX backslope varies from 3:1 to 6:1 from STA. 109+95.71 "43SBEX" to STA. 121+25.95 "43SBEX"

- Notes:**
- See DET-01 for Legend and Variable Width Table.
 - Cross slope varies. See Cross Sections for varying slopes.

NOTE TO REVIEWER:

Pavement design assumed to be asphalt for estimating purposes. Pavement design to be approved in a future submittal.

NOTE TO REVIEWER:

Safety Edge detail to be provided in a future submittal.

DRAFT
NOT FOR CONSTRUCTION

RECOMMENDED FOR APPROVAL _____	DESIGN ENGINEER _____	DATE _____
DESIGNED: _____ DCK _____	DRAWN: _____ DCK _____	
CHECKED: _____ MKM _____	CHECKED: _____ MKM _____	

INDIANA
DEPARTMENT OF TRANSPORTATION

TYPICAL CROSS SECTIONS
SR 43 RAMPS

HORIZONTAL SCALE	BRIDGE FILE
3/16"=1'-0"	N/A
VERTICAL SCALE	DESIGNATION
N/A	2001172 & 2100049
SURVEY BOOK	SHEETS
ELECTRONIC	13 of 536
CONTRACT	PROJECT
R-42909	2001172 & 2100049

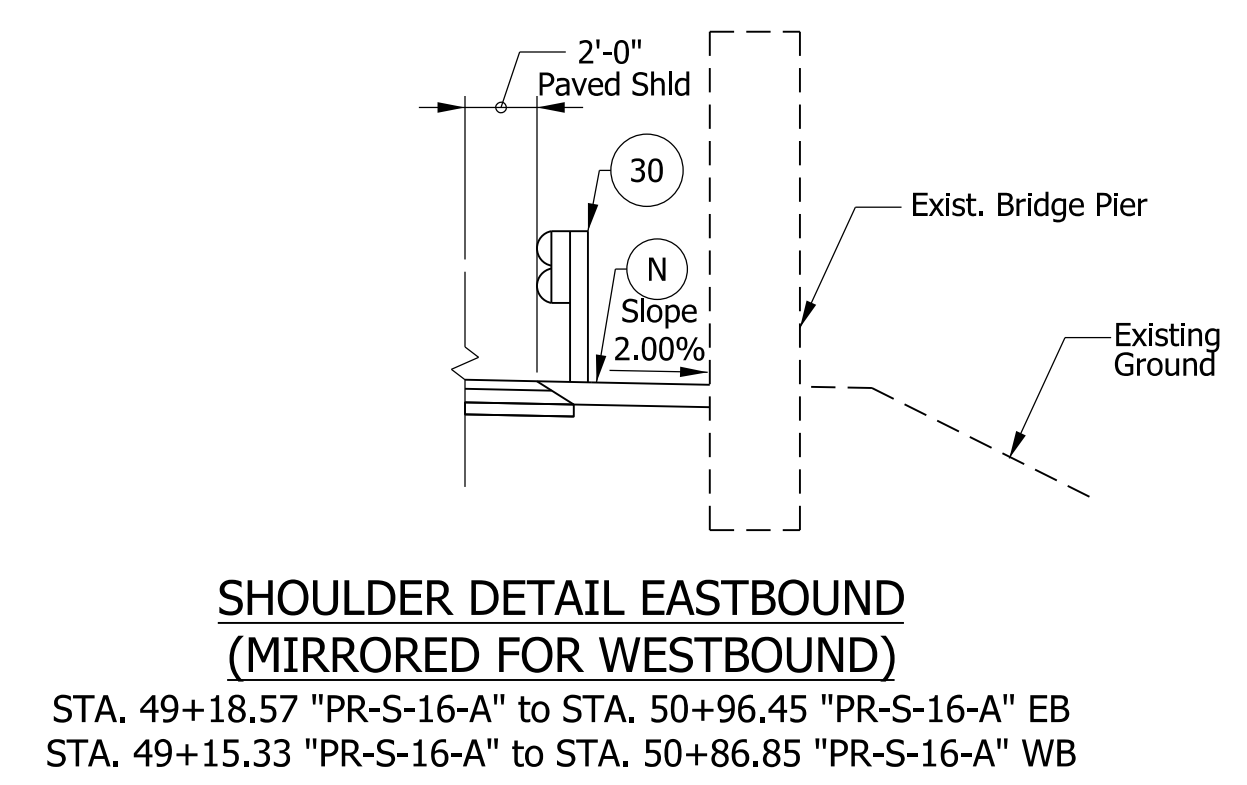
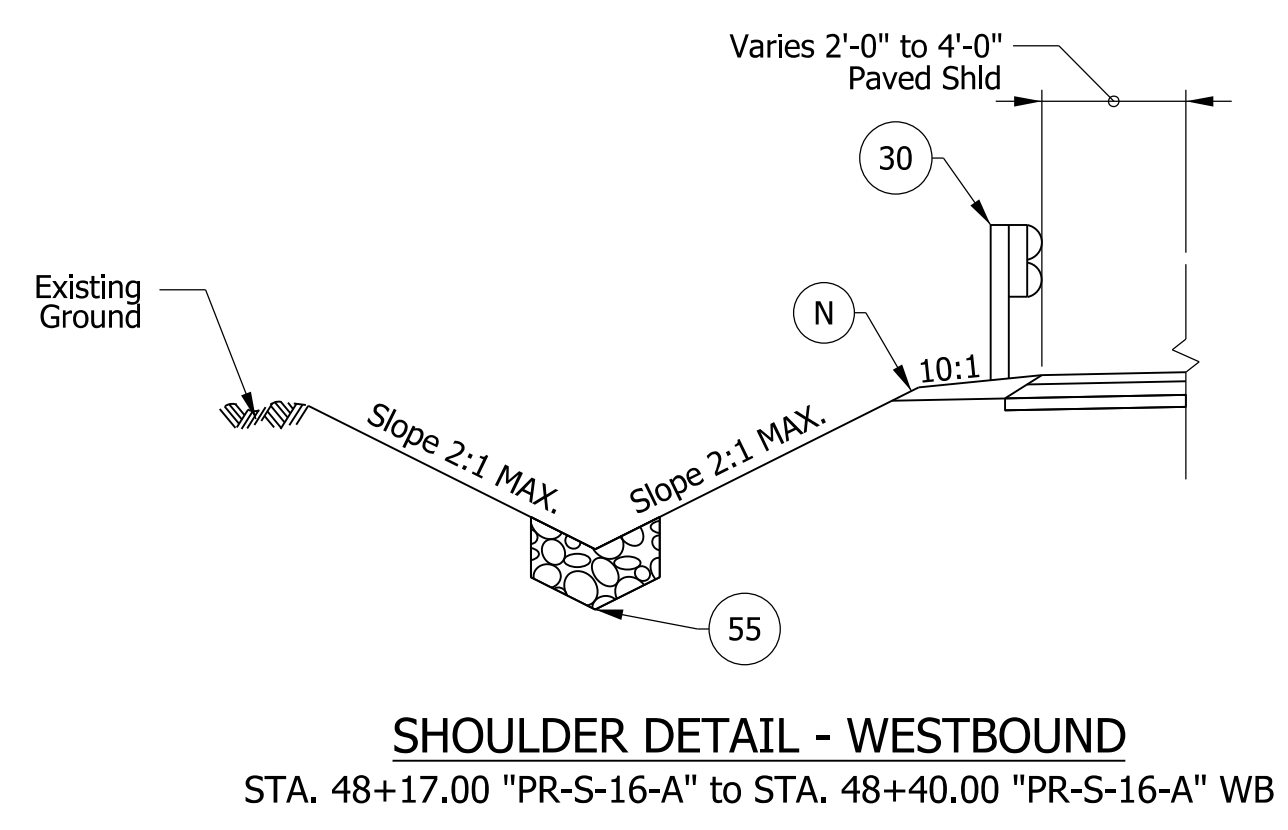
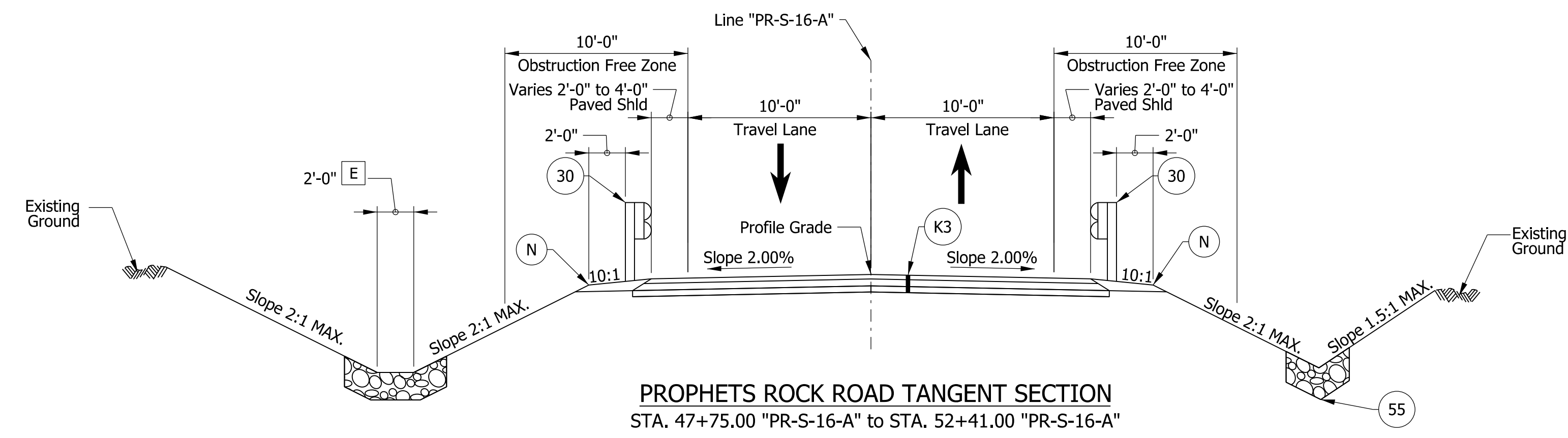
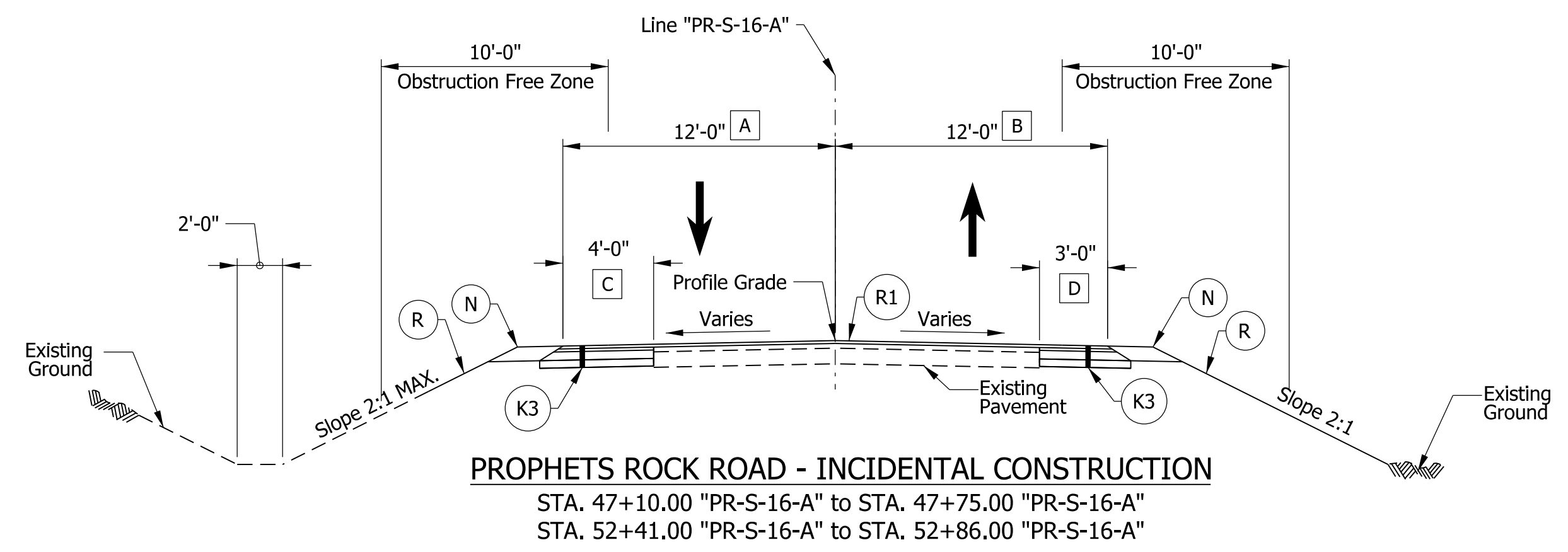

- Notes:**
- See DET-01 for Legend and Variable Width Table.
 - See Cross Sections for varying slopes.
- A** Width varies from 10'-0" to 12'-0" from STA. 47+10.00 "PR-S-16-A" to STA. 47+75.00 "PR-S-16-A".
Width varies from 12'-0" to 10'-8" from STA. 52+41.00 "PR-S-16-A" to STA. 52+86.00 "PR-S-16-A".
 - B** Width varies from 11'-0" to 12'-0" from STA. 47+10.00 "PR-S-16-A" to STA. 47+75.00 "PR-S-16-A".
Width varies from 12'-0" to 10'-1" from STA. 52+41.00 "PR-S-16-A" to STA. 52+86.00 "PR-S-16-A".
 - C** Width varies from 2'-0" to 4'-0" from STA. 47+10.00 "PR-S-16-A" to STA. 47+75.00 "PR-S-16-A".
Width varies from 3'-6" to 2'-2" from STA. 52+41.00 "PR-S-16-A" to STA. 52+86.00 "PR-S-16-A".
 - D** Width varies from 2'-0" to 3'-0" from STA. 47+10.00 "PR-S-16-A" to STA. 47+75.00 "PR-S-16-A".
Width varies from 4'-0" to 2'-1" from STA. 52+41.00 "PR-S-16-A" to STA. 52+86.00 "PR-S-16-A".
 - E** Width varies from 0'-0" to 2'-0" from STA. 48+40.00 "PR-S-16-A" to STA. 49+00.00 "PR-S-16-A" WB.

rstriegel
 1/20/2021 10:46:42 am
 model:Sheet14
 file: c:\candib\pwr\striegel\pwr\great_lakes\02403851\2001172-rd-s-hyp01.dgn

NOTE TO REVIEWER:
 Pavement design assumed to be asphalt for estimating purposes. Pavement design to be approved in a future submittal.

NOTE TO REVIEWER:
 Safety Edge detail to be provided in a future submittal.

DRAFT
NOT FOR CONSTRUCTION

RECOMMENDED FOR APPROVAL _____	DESIGN ENGINEER _____	DATE _____
DESIGNED: _____ DCK _____	DRAWN: _____ DCK _____	
CHECKED: _____ MKM _____	CHECKED: _____ MKM _____	

INDIANA DEPARTMENT OF TRANSPORTATION

**TYPICAL CROSS SECTIONS
PROPHETS ROCK ROAD**

HORIZONTAL SCALE	BRIDGE FILE
3/16"=1'-0"	N/A
VERTICAL SCALE	DESIGNATION
N/A	2001172 & 2100049
SURVEY BOOK	SHEETS
ELECTRONIC	14 of 536
CONTRACT	PROJECT
R-42909	2001172 & 2100049

I-65 ATL PLAN SHEETS

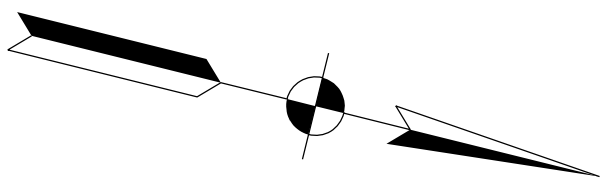

BEGIN PROJECT
 PROJECT NO. 2001172
 P.O.C. STA. 822+10.00
 LINE "PR-A"
 N: 219247.37
 E: 800040.43

END PROJECT
 PROJECT NO. 2001172
 P.O.C. STA. 1036+03.00
 LINE "PR-A"
 N: 235228.49
 E: 787655.78

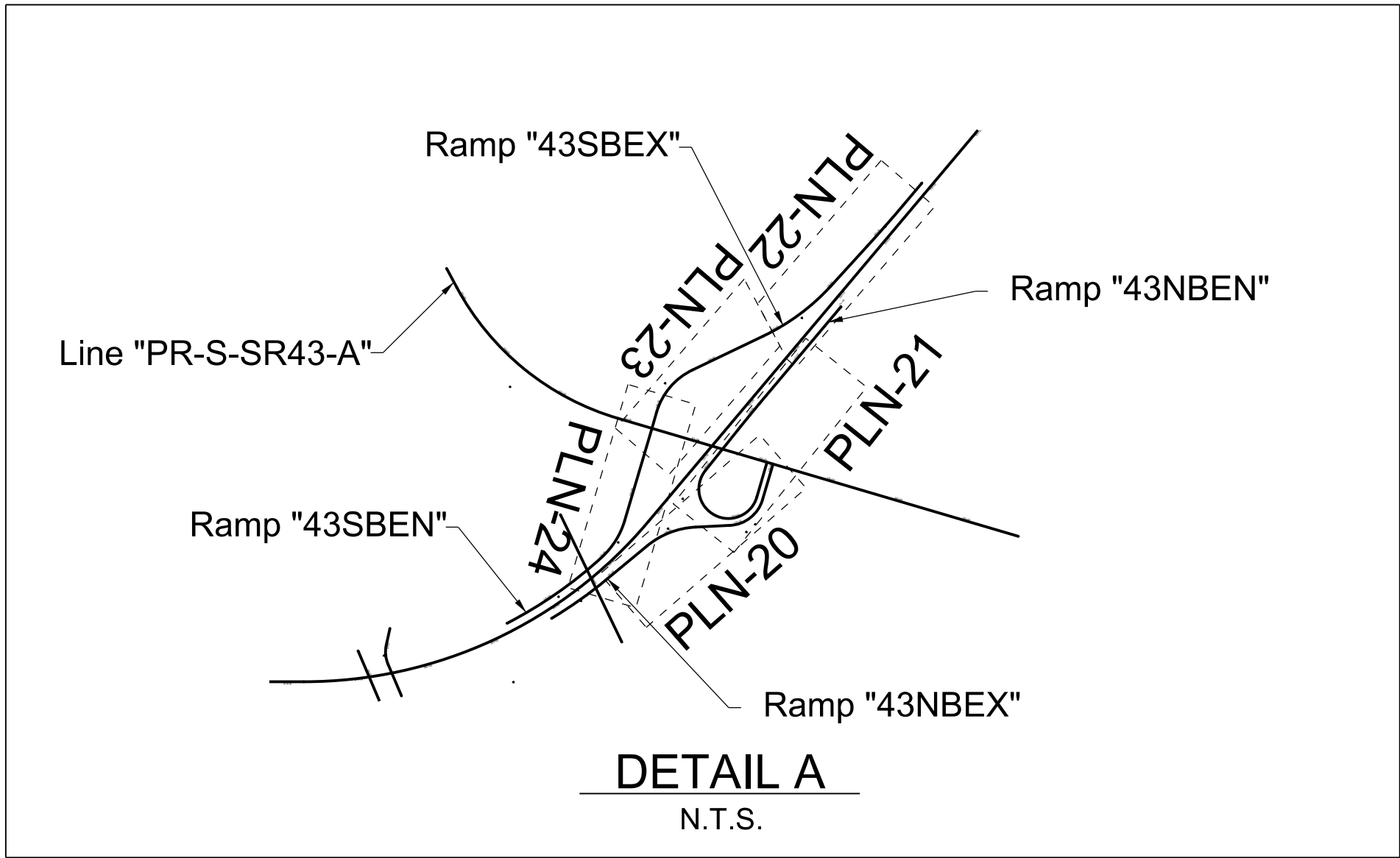
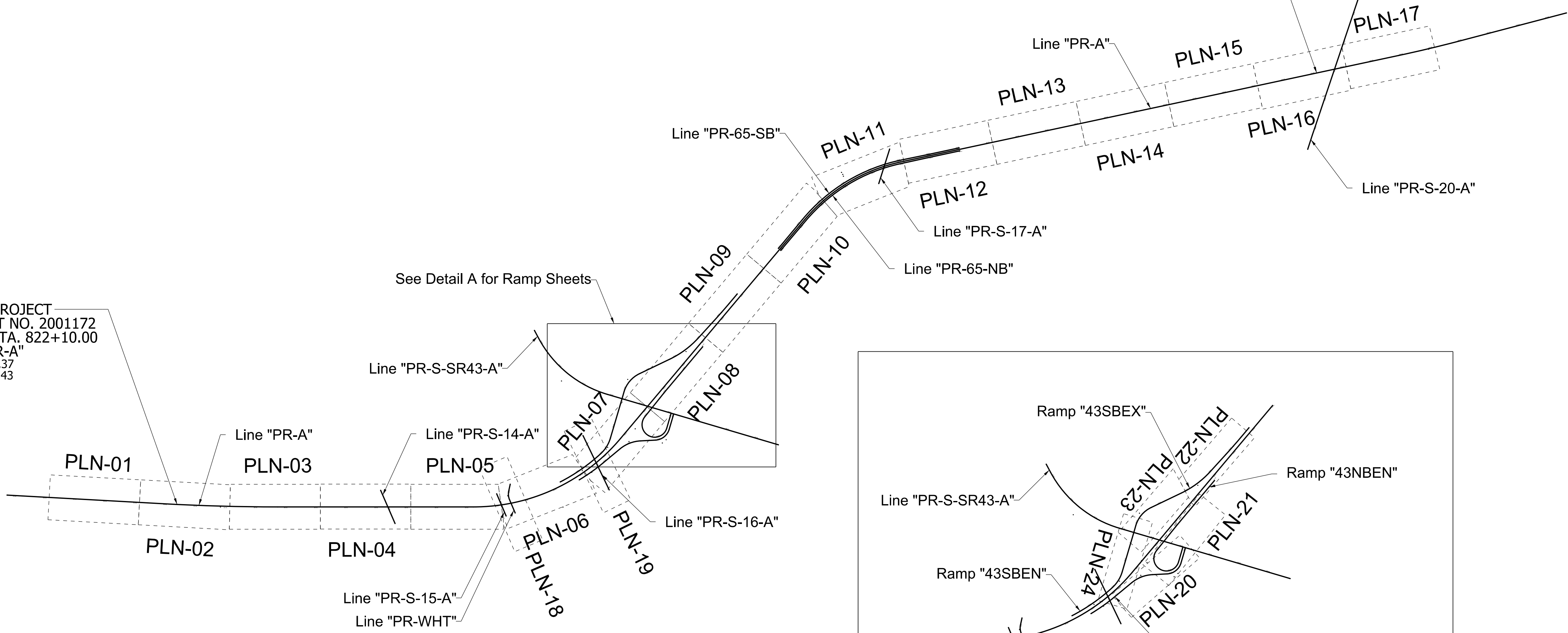

rstriegel
 9/29/2020 12:07:41 pm
 model: Sheet1
 file: c:\cadd\ib\pvt\cebutler\gmaatkes\02-40385\2001172-rd-s-i\01.dgn

DRAFT
NOT FOR CONSTRUCTION

RECOMMENDED FOR APPROVAL _____ DESIGN ENGINEER _____ DATE _____	
DESIGNED: _____ RJS _____ DRAWN: _____ RJS _____	
CHECKED: _____ MKM _____ CHECKED: _____ MKM _____	

INDIANA DEPARTMENT OF TRANSPORTATION	
PLAN SHEET KEYMAP	
PLN-01 THRU PLN-24	

HORIZONTAL SCALE	BRIDGE FILE
1"=1000'	N/A
VERTICAL SCALE	DESIGNATION
N/A	2001172 & 2100049
SURVEY BOOK	SHEETS
ELECTRONIC	IX-01
CONTRACT	117 of 536
R-42909	PROJECT
	2001172 & 2100049

rstriegel
 9/30/2020 3:23:55 pm
 model:Sheet1
 file: c:\cadd\ib\p\cadd\ib\g\greatakes\002\0385\2001172-rd-s-pln01.dgn

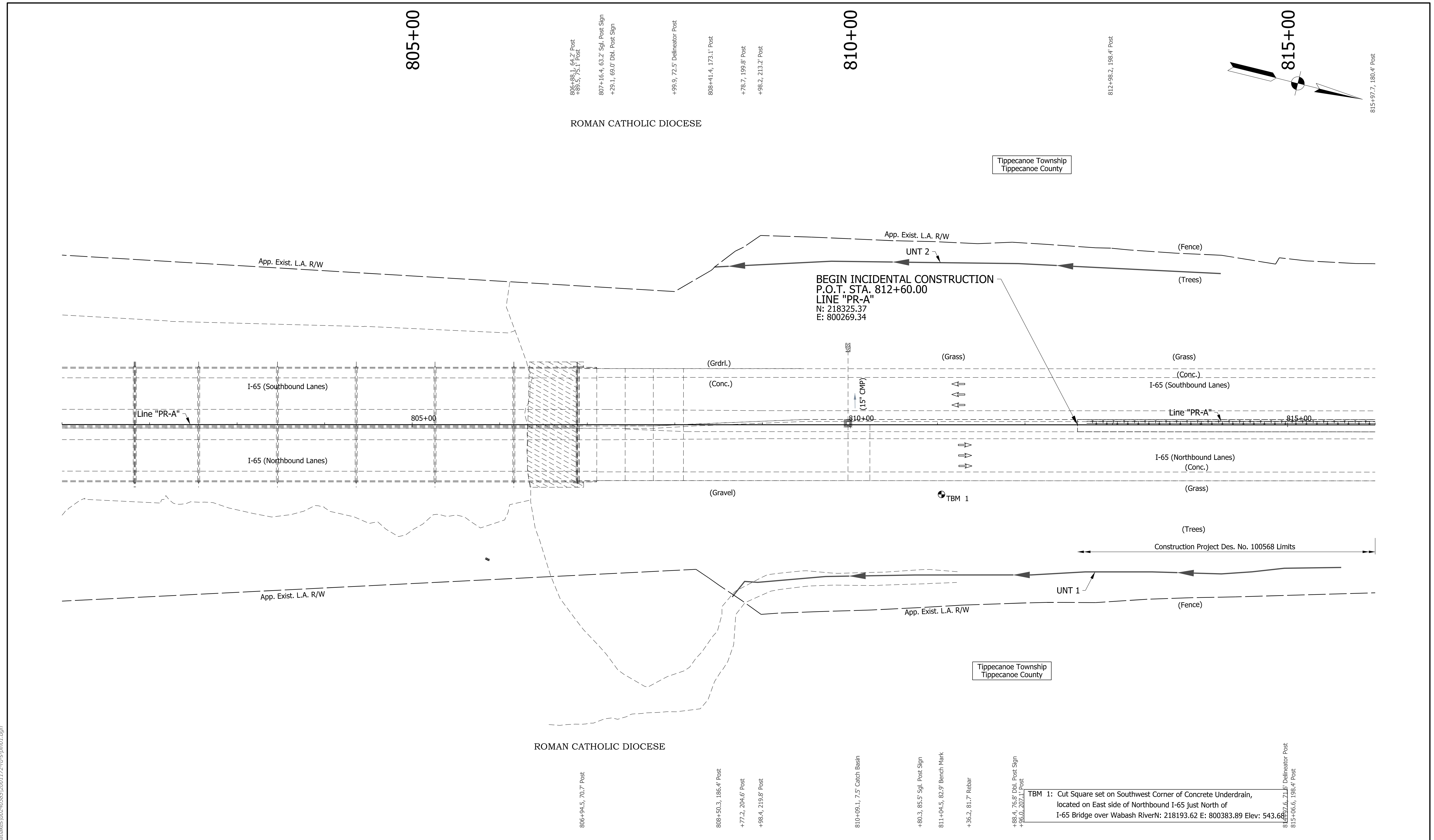

- Notes:**
- Existing topography notes taken from Line "PR-A".
 - For geometric information, see Geometric Layout Sheets.
 - For control point information, see Reference Tie Sheets.
 - Line "PR-A" to be constructed.

DRAFT
 NOT FOR CONSTRUCTION

RECOMMENDED FOR APPROVAL _____	DESIGN ENGINEER _____	DATE _____
DESIGNED: _____ JMA _____	DRAWN: _____ CEB _____	
CHECKED: _____ MKM _____	CHECKED: _____ MKM _____	

INDIANA
DEPARTMENT OF TRANSPORTATION

PLAN SHEET
LINE "PR-A"
STA. 801+00 TO STA. 816+00

HORIZONTAL SCALE	BRIDGE FILE
1"=50'	N/A
VERTICAL SCALE	DESIGNATION
N/A	2001172 & 2100049
SURVEY BOOK	SHEETS
ELECTRONIC	118 of 536
CONTRACT	PROJECT
R-42909	2001172 & 2100049

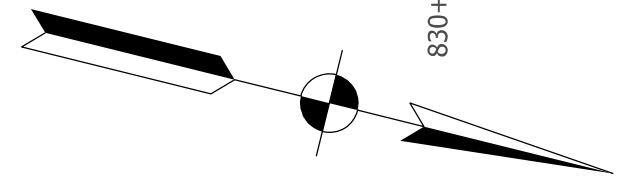
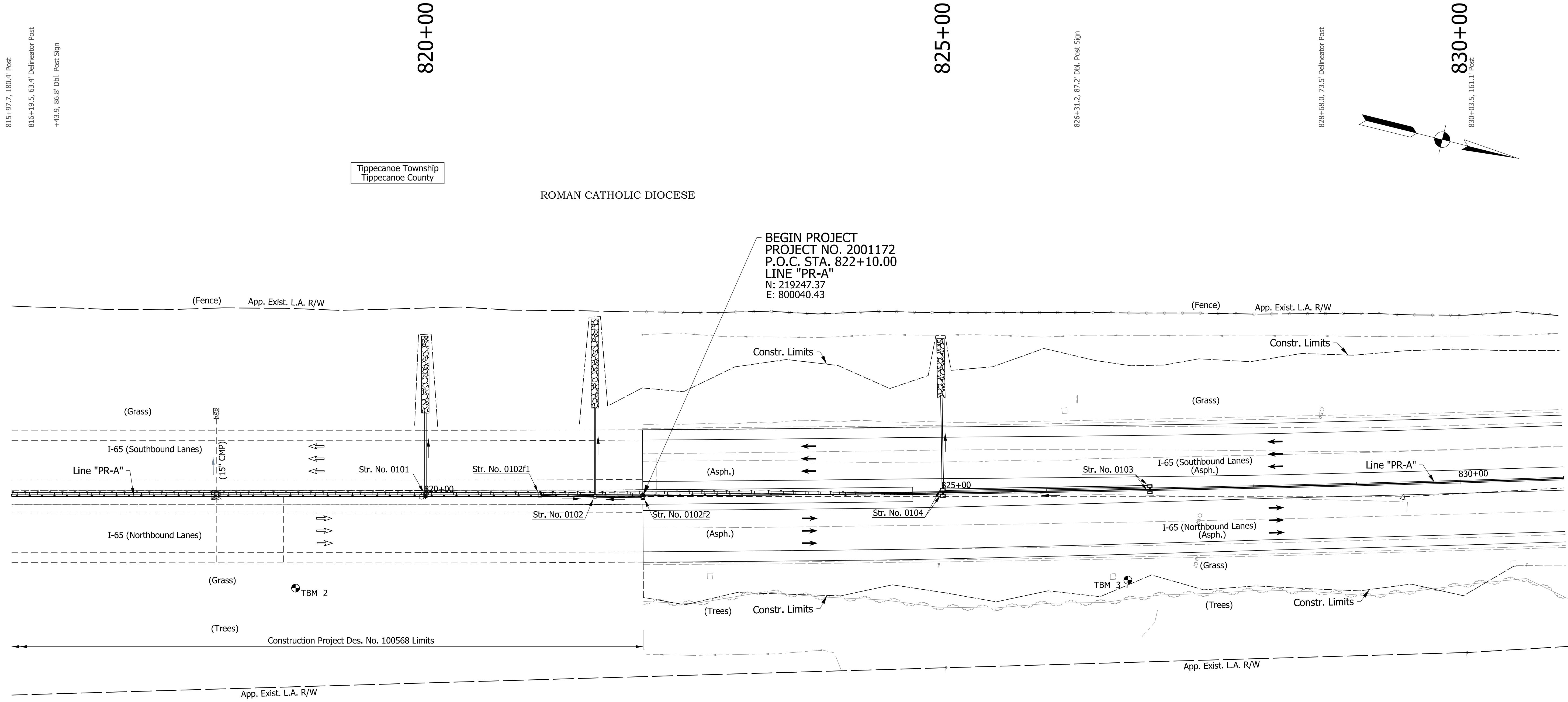

TBM 2: Cut "X" set on Northwest Bolt of West Post of "Food-Exit 178" Sign, located on East side of Northbound I-65 N: 218943.08 E: 800207.63, Elev: 538.62

TBM 3: Cut "X" set on Northwest Bolt of West Post of "Gas/Attraction" Combination Exit 178 Sign located on East side of Northbound I-65 N: 219721.97 E: 800006.59, Elev: 539.15

- Notes:**
- Existing topography notes taken from Line "PR-A".
 - For geometric information, see Geometric Layout Sheets.
 - For control point information, see Reference Tie Sheets.
 - Line "PR-A" to be constructed.

DRAFT
NOT FOR CONSTRUCTION

RECOMMENDED FOR APPROVAL _____	DESIGN ENGINEER _____	DATE _____
DESIGNED: _____ JMA _____	DRAWN: _____ CEB _____	
CHECKED: _____ MKM _____	CHECKED: _____ MKM _____	

INDIANA
DEPARTMENT OF TRANSPORTATION

PLAN SHEET
LINE "PR-A"
STA. 816+00 TO STA. 831+00

HORIZONTAL SCALE	BRIDGE FILE
1"=50'	N/A
VERTICAL SCALE	DESIGNATION
N/A	2001172 & 2100049
SURVEY BOOK	SHEETS
ELECTRONIC	120 of 536
CONTRACT	PROJECT
R-42909	2001172 & 2100049

cebutler
 9/30/2020 3:23:55 pm
 model:Sheet2
 file: c:\cadd\ib\p\cebutler\gmat\akes\002\0385\2001172-rd-rs-pln01.dgn

rstriegel
 9/30/2020 3:23:55 pm
 model:Sheet3
 file: c:\cadd\ib\pvt\cadd\ib\greatlakes\02-40385\2001172-rd-s-pln01.dgn

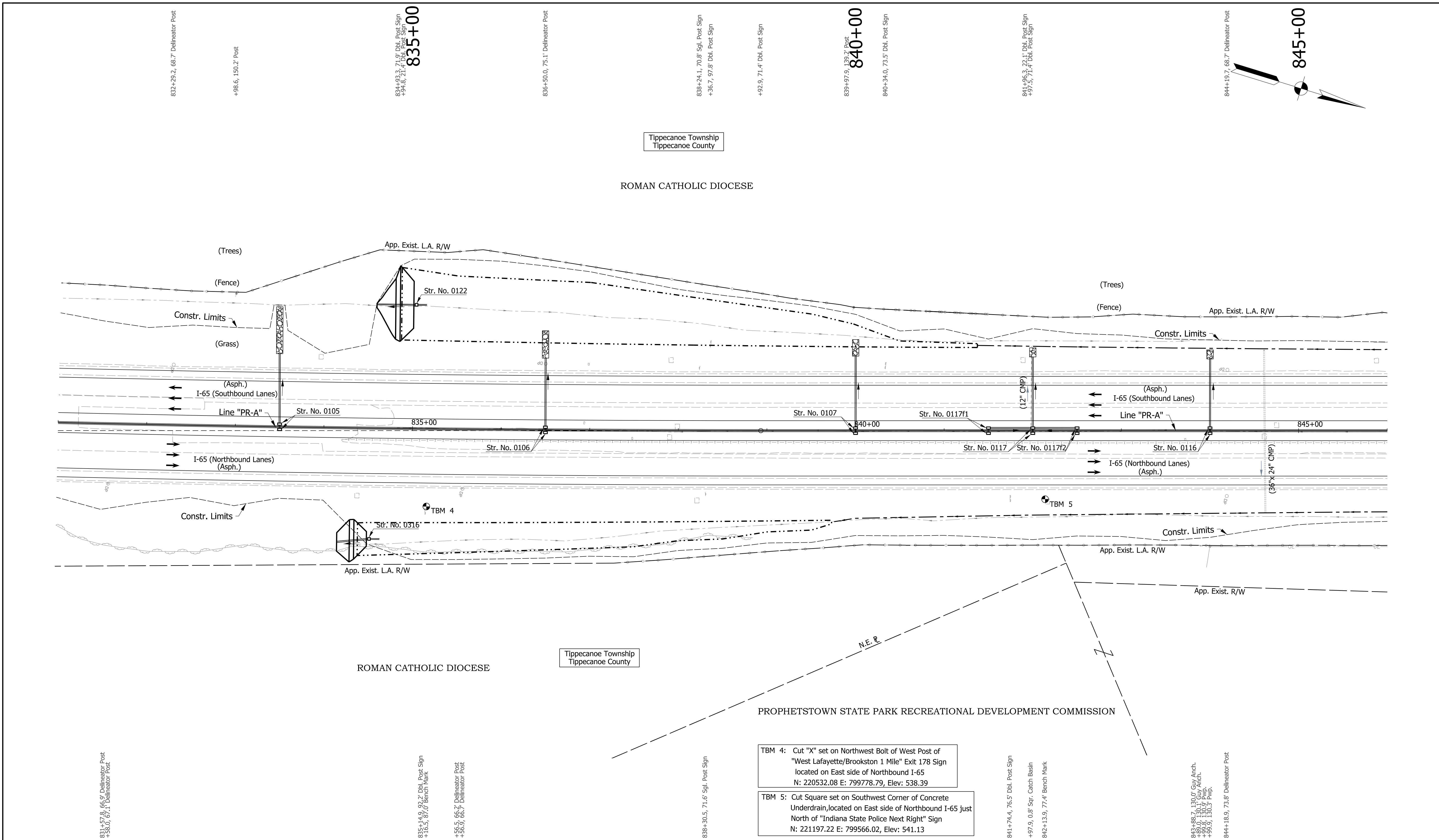

- Notes:**
- Existing topography notes taken from Line "PR-A".
 - For geometric information, see Geometric Layout Sheets.
 - For control point information, see Reference Tie Sheets.
 - Line "PR-A" to be constructed.

DRAFT NOT FOR CONSTRUCTION	RECOMMENDED FOR APPROVAL _____	DESIGN ENGINEER _____	DATE _____
	DESIGNED: _____ JMA _____	DRAWN: _____ CEB _____	
	CHECKED: _____ MKM _____	CHECKED: _____ MKM _____	

INDIANA DEPARTMENT OF TRANSPORTATION

PLAN SHEET
LINE "PR-A"
STA. 831+00 TO STA. 846+00

HORIZONTAL SCALE	BRIDGE FILE
1"=50'	N/A
VERTICAL SCALE	DESIGNATION
N/A	2001172 & 2100049
SURVEY BOOK	SHEETS
ELECTRONIC	122 of 536
CONTRACT	PROJECT
R-42909	2001172 & 2100049

TBM 4: Cut "X" set on Northwest Bolt of West Post of "West Lafayette/Brookston 1 Mile" Exit 178 Sign located on East side of Northbound I-65
 N: 220532.08 E: 799778.79, Elev: 538.39

TBM 5: Cut Square set on Southwest Corner of Concrete Underdrain, located on East side of Northbound I-65 just North of "Indiana State Police Next Right" Sign
 N: 221197.22 E: 799566.02, Elev: 541.13

rstriegel
9/30/2020 3:23:55 pm
model-Sheet4
file:c:\cadd\ib\pvc\butler\greatakes\02\0385\2001172-rd-s-pln01.dgn

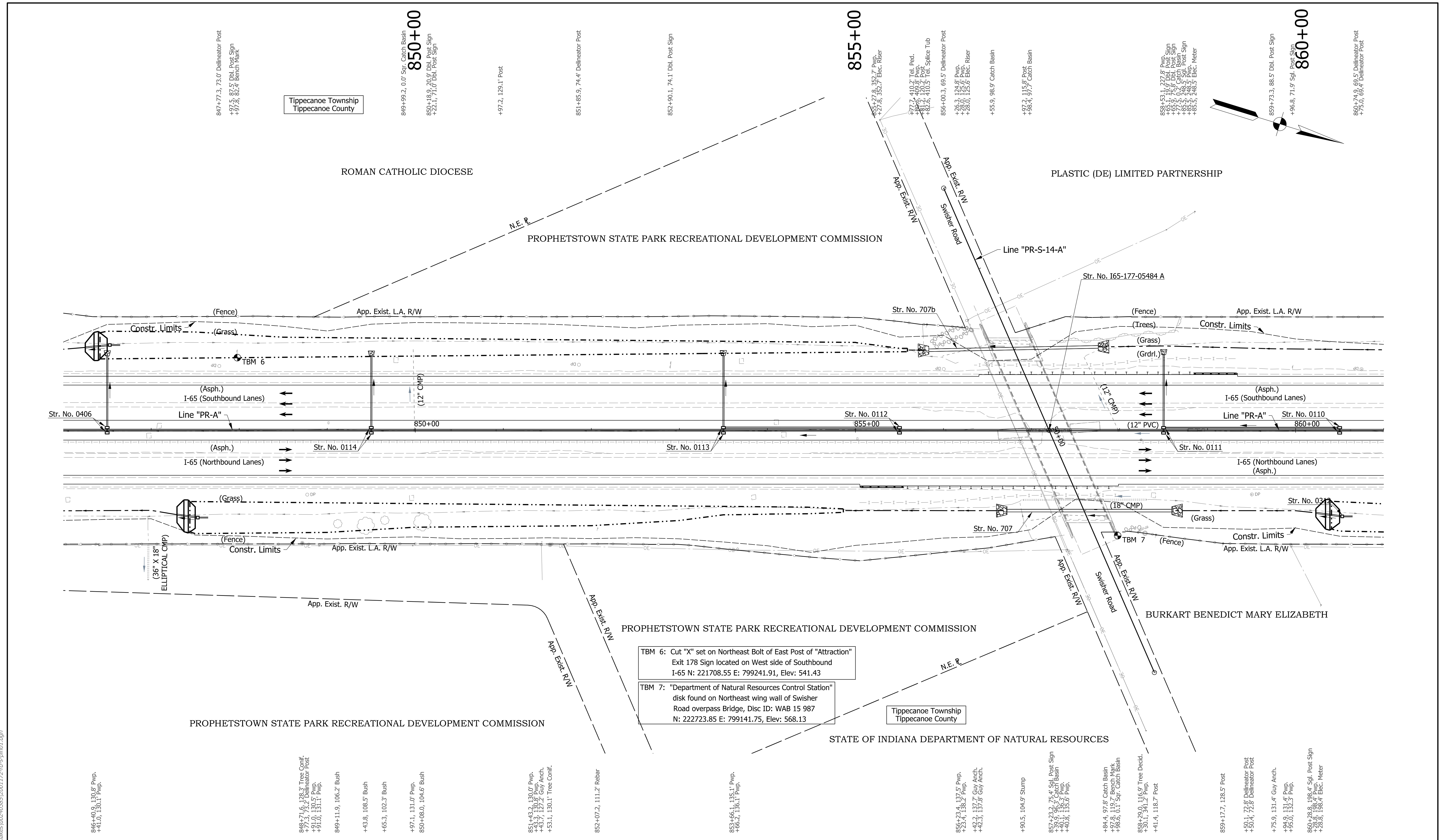

- Notes:**
- Existing topography notes taken from Line "PR-A".
 - For geometric information, see Geometric Layout Sheets.
 - For control point information, see Reference Tie Sheets.
 - Line "PR-A" to be constructed.

TBM 6: Cut "X" set on Northeast Bolt of East Post of "Attraction" Exit 178 Sign located on West side of Southbound I-65 N: 221708.55 E: 799241.91, Elev: 541.43

TBM 7: "Department of Natural Resources Control Station" disk found on Northeast wing wall of Swisher Road overpass Bridge, Disc ID: WAB 15 987 N: 222723.85 E: 799141.75, Elev: 568.13

DRAFT
NOT FOR CONSTRUCTION

RECOMMENDED FOR APPROVAL	DESIGN ENGINEER	DATE
DESIGNED: JMA	DRAWN: CEB	
CHECKED: MKM	CHECKED: MKM	

INDIANA DEPARTMENT OF TRANSPORTATION

PLAN SHEET
LINE "PR-A"
STA. 846+00 TO STA. 861+00

HORIZONTAL SCALE	BRIDGE FILE
1"=50'	N/A
VERTICAL SCALE	DESIGNATION
N/A	2001172 & 2100049
SURVEY BOOK	SHEETS
ELECTRONIC	124 of 536
CONTRACT	PROJECT
R-42909	2001172 & 2100049

cebutler
9/30/2020 3:23:55 pm
model-Sheet45
file:c:\candib\p\cebutler\gmatkakes\002\0385\2001172-rd-s-pln01.dgn

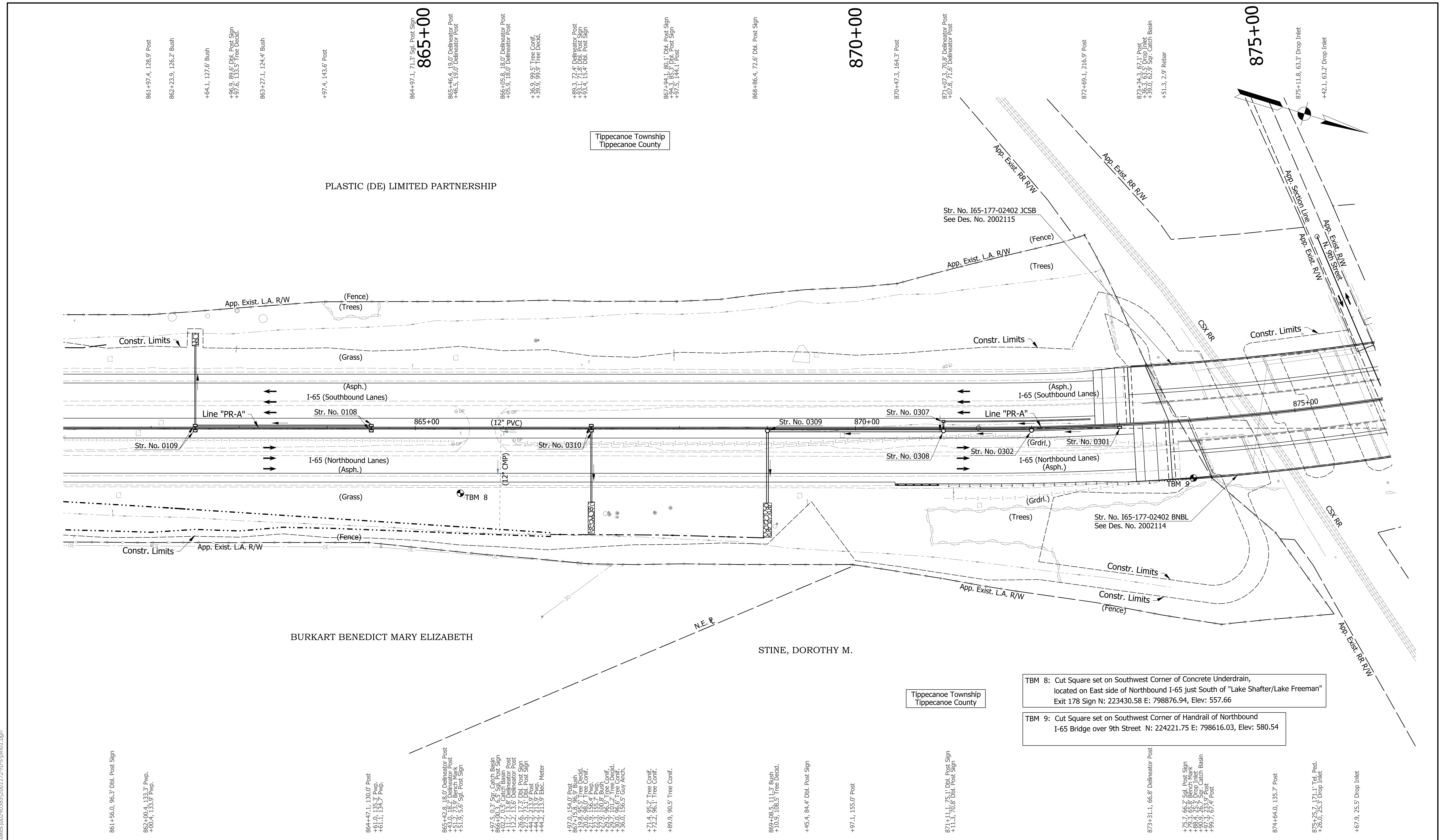

- Notes:**
- Existing topography notes taken from Line "PR-A".
 - For geometric information, see Geometric Layout Sheets.
 - For control point information, see Reference Tie Sheets.
 - Line "PR-A" to be constructed.

DRAFT
NOT FOR CONSTRUCTION

RECOMMENDED FOR APPROVAL	DESIGN ENGINEER	DATE
DESIGNED: JMA	DRAWN: CEB	
CHECKED: MKM	CHECKED: MKM	

INDIANA
DEPARTMENT OF TRANSPORTATION

PLAN SHEET
LINE "PR-A"
STA. 861+00 TO STA. 876+00

HORIZONTAL SCALE	BRIDGE FILE
1"=50'	N/A
VERTICAL SCALE	DESIGNATION
N/A	2001172 & 2100049
SURVEY BOOK	SHEETS
ELECTRONIC	126 of 536
CONTRACT	PROJECT
R-42909	2001172 & 2100049

TBM 8: Cut Square set on Southwest Corner of Concrete Underdrain, located on East side of Northbound I-65 just South of "Lake Shafter/Lake Freeman" Exit 178 Sign N: 223430.58 E: 798876.94, Elev: 557.66

TBM 9: Cut Square set on Southwest Corner of Handrail of Northbound I-65 Bridge over 9th Street N: 224221.75 E: 798616.03, Elev: 580.54

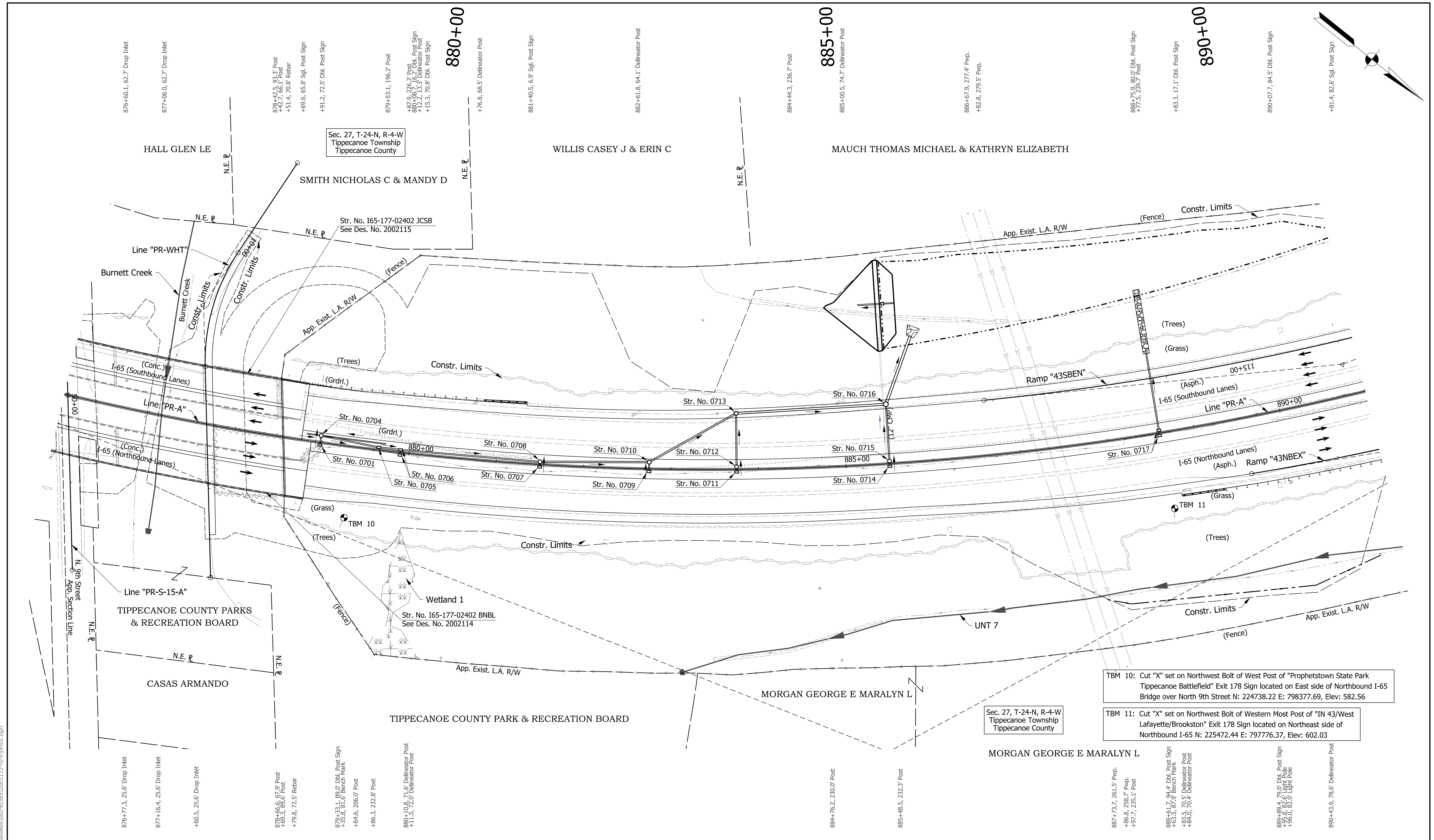

- Notes:**
- Existing topography notes taken from Line "PR-A".
 - For geometric information, see Geometric Layout Sheets.
 - For control point information, see Reference Tie Sheets.
 - Line "PR-A" to be constructed.

DRAFT
NOT FOR CONSTRUCTION

RECOMMENDED FOR APPROVAL	DESIGN ENGINEER	DATE
DESIGNED: JMA	DRAWN: CEB	
CHECKED: MKM	CHECKED: MKM	

INDIANA
DEPARTMENT OF TRANSPORTATION

PLAN SHEET
LINE "PR-A"
STA. 876+00 TO STA. 891+00

HORIZONTAL SCALE	BRIDGE FILE
1"=50'	N/A
VERTICAL SCALE	DESIGNATION
N/A	2001172 & 2100049
SURVEY BOOK	SHEETS
ELECTRONIC	128 of 536
CONTRACT	PROJECT
R-42909	2001172 & 2100049

cebutler
 9/30/2020 3:23:55 pm
 model: Sheet6
 file: c:\candlib\p\cebutler\greatakes\002\0385\2001172-rd-s-pln01.dgn

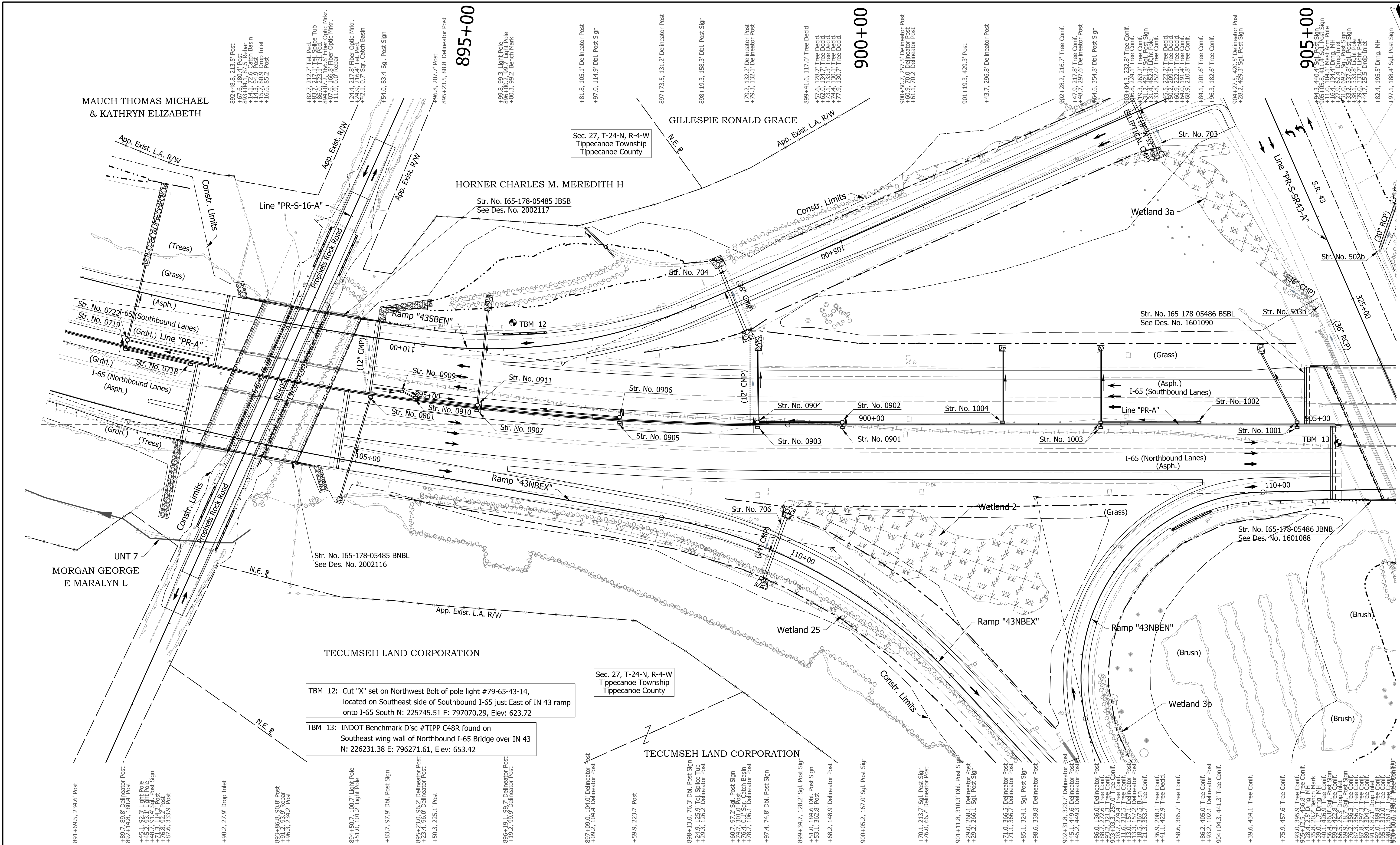

- Notes:**
- Existing topography notes taken from Line "PR-A".
 - For geometric information, see Geometric Layout Sheets.
 - For control point information, see Reference Tie Sheets.
 - Line "PR-A" to be constructed.

TBM 12: Cut "X" set on Northwest Bolt of pole light #79-65-43-14, located on Southeast side of Southbound I-65 just East of IN 43 ramp onto I-65 South N: 225745.51 E: 797070.29, Elev: 623.72

TBM 13: INDOT Benchmark Disc #TIPP C48R found on Southeast wing wall of Northbound I-65 Bridge over IN 43 N: 226231.38 E: 796271.61, Elev: 653.42

DRAFT
NOT FOR CONSTRUCTION

RECOMMENDED FOR APPROVAL	DESIGN ENGINEER	DATE
DESIGNED: JMA	DRAWN: CEB	
CHECKED: MKM	CHECKED: MKM	

INDIANA DEPARTMENT OF TRANSPORTATION

PLAN SHEET
LINE "PR-A"
STA. 891+00 TO STA. 906+00

HORIZONTAL SCALE	BRIDGE FILE	
1"=50'	N/A	
VERTICAL SCALE	DESIGNATION	
N/A	2001172 & 2100049	
SURVEY BOOK	SHEETS	PLN-07
ELECTRONIC	130	of 536
CONTRACT	PROJECT	
R-42909	2001172 & 2100049	

cebutler
 9/30/2020 3:23:55 pm
 model:Sheet7
 file:c:\candib\p\cebutler\gmat\kikes\002\0385\2001172-rd-s-pln01.dgn

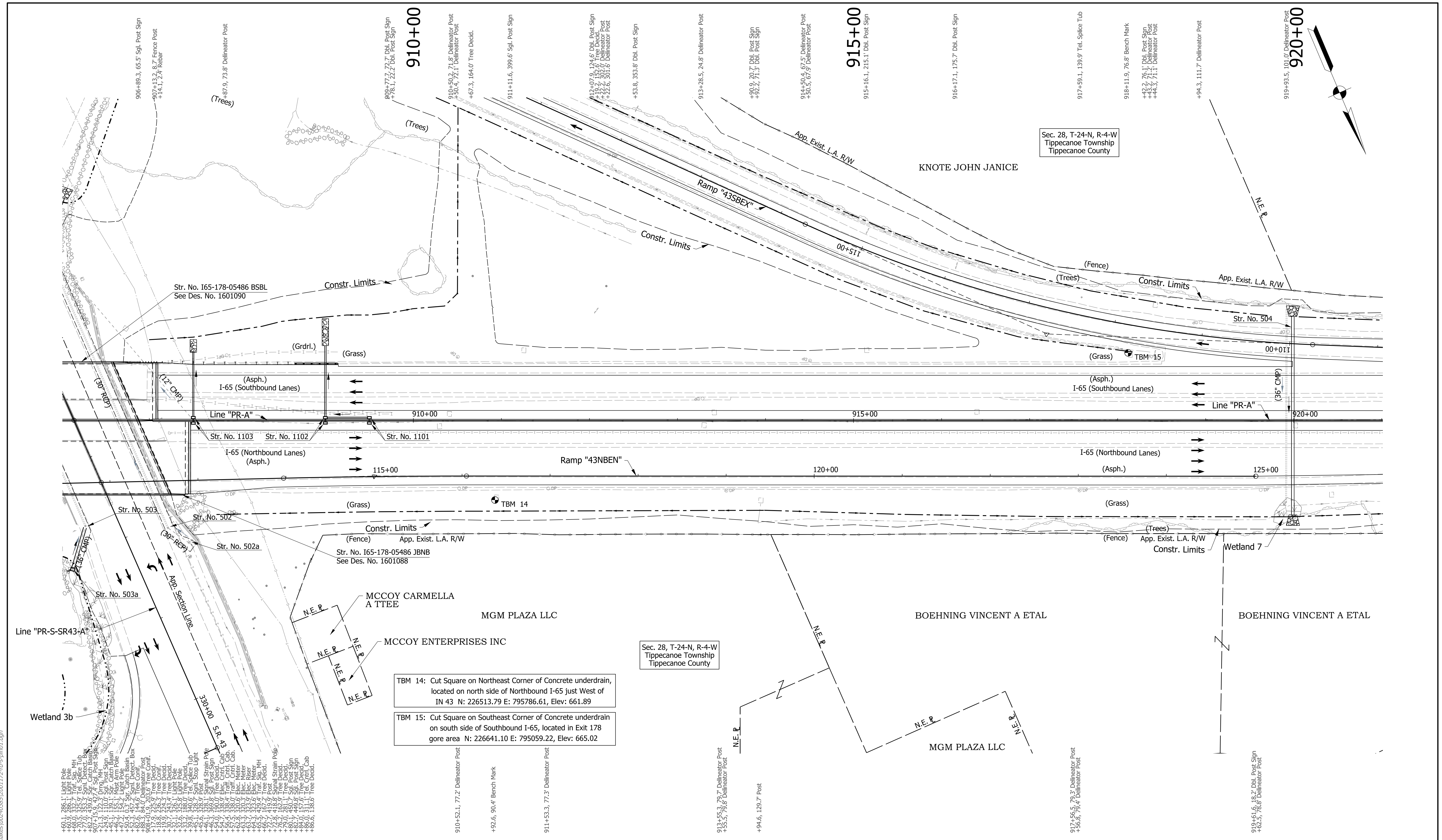

- Notes:**
- Existing topography notes taken from Line "PR-A".
 - For geometric information, see Geometric Layout Sheets.
 - For control point information, see Reference Tie Sheets.
 - Line "PR-A" to be constructed.

TBM 14: Cut Square on Northeast Corner of Concrete underdrain, located on north side of Northbound I-65 just West of IN 43 N: 226513.79 E: 795786.61, Elev: 661.89

TBM 15: Cut Square on Southeast Corner of Concrete underdrain on south side of Southbound I-65, located in Exit 178 gore area N: 226641.10 E: 795059.22, Elev: 665.02

DRAFT
NOT FOR CONSTRUCTION

RECOMMENDED FOR APPROVAL	DESIGN ENGINEER	DATE
DESIGNED: JMA	DRAWN: CEB	
CHECKED: MKM	CHECKED: MKM	

INDIANA
DEPARTMENT OF TRANSPORTATION

PLAN SHEET
LINE "PR-A"
STA. 906+00 TO STA. 921+00

HORIZONTAL SCALE	BRIDGE FILE
1"=50'	N/A
VERTICAL SCALE	DESIGNATION
N/A	2001172 & 2100049
SURVEY BOOK	SHEETS
ELECTRONIC	132 of 536
CONTRACT	PROJECT
R-42909	2001172 & 2100049

cebutler
 9/30/2020 3:23:55 pm
 model:Sheet8
 file:c:\cadd\ib\p\cebutler\gmat\kikes\002\0385\2001172-rd-s-pln01.dgn

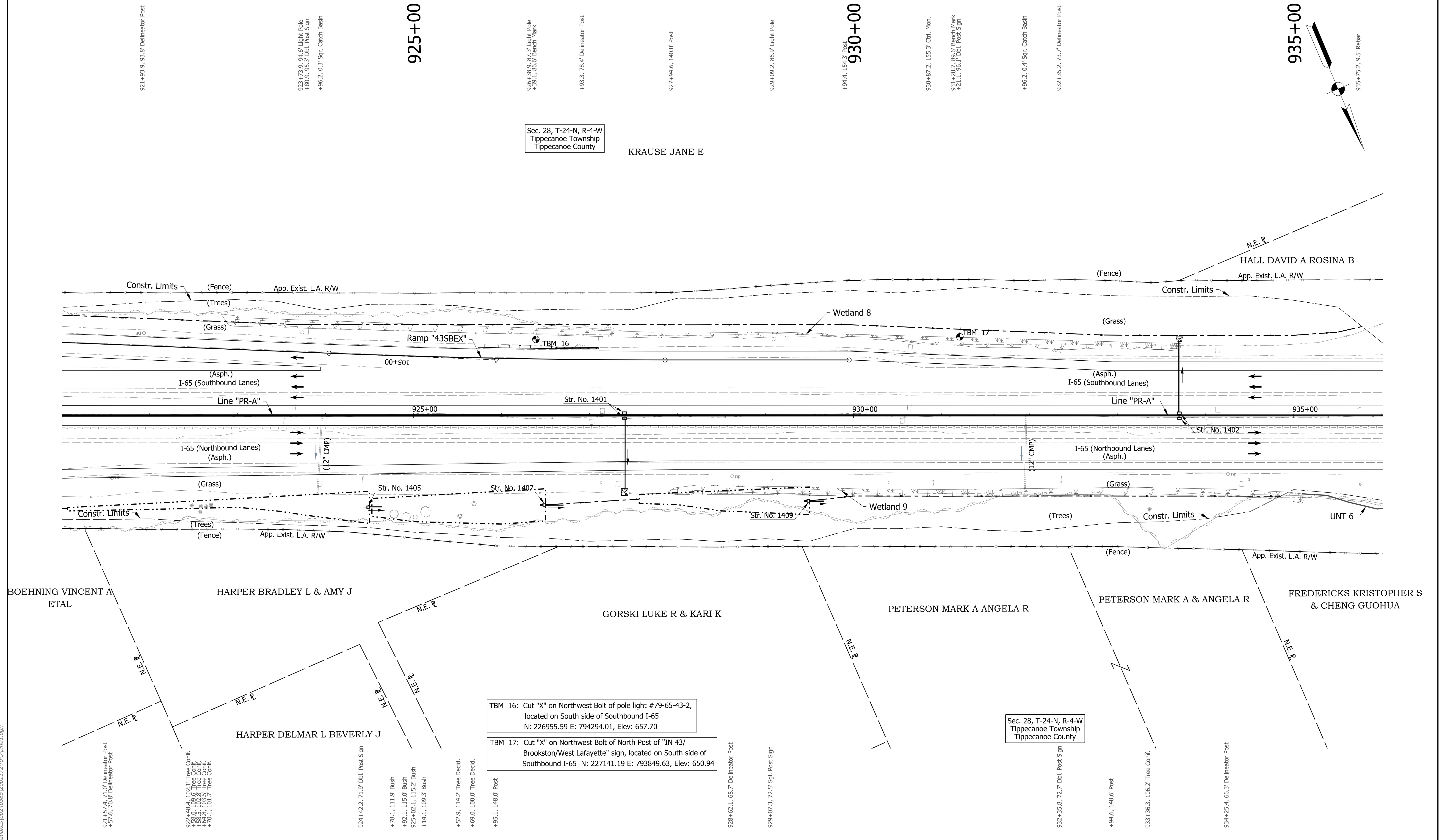

Sec. 28, T-24-N, R-4-W
Tippecanoe Township
Tippecanoe County

KRAUSE JANE E

Sec. 28, T-24-N, R-4-W
Tippecanoe Township
Tippecanoe County

TBM 16: Cut "X" on Northwest Bolt of pole light #79-65-43-2,
located on South side of Southbound I-65
N: 226955.59 E: 794294.01, Elev: 657.70

TBM 17: Cut "X" on Northwest Bolt of North Post of "IN 43/
Brookston/West Lafayette" sign, located on South side of
Southbound I-65 N: 227141.19 E: 793849.63, Elev: 650.94

- Notes:**
- Existing topography notes taken from Line "PR-A".
 - For geometric information, see Geometric Layout Sheets.
 - For control point information, see Reference Tie Sheets.
 - Line "PR-A" to be constructed.

DRAFT
NOT FOR CONSTRUCTION

RECOMMENDED FOR APPROVAL	DESIGN ENGINEER	DATE
DESIGNED: JMA	DRAWN: CEB	
CHECKED: MKM	CHECKED: MKM	

INDIANA
DEPARTMENT OF TRANSPORTATION

PLAN SHEET
LINE "PR-A"
STA. 921+00 TO STA. 936+00

HORIZONTAL SCALE	BRIDGE FILE
1"=50'	N/A
VERTICAL SCALE	DESIGNATION
N/A	2001172 & 2100049
SURVEY BOOK	SHEETS
ELECTRONIC	134 of 536
CONTRACT	PROJECT
R-42909	2001172 & 2100049

cebutler
 9/30/2020 3:23:55 pm
 model:Sheet9
 file:c:\cadd\ib\p\cebutler\gmat\akes\002\03285\2001172-rd-rs-pln01.dgn

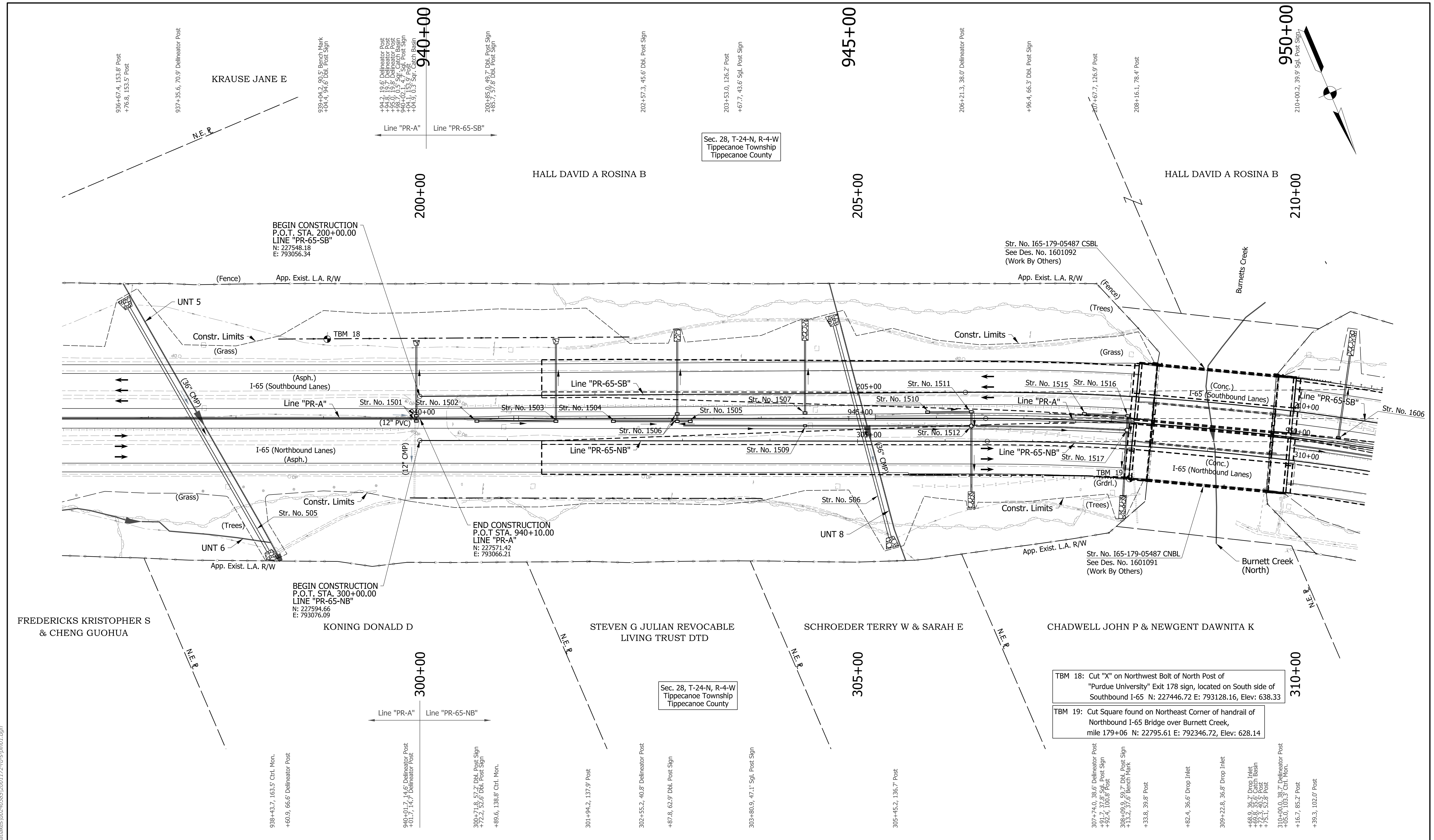

- Notes:**
- Existing topography notes taken from Line "PR-A" up to Sta. 940+10.00. Existing topography notes taken from Line "PR-65-SB" and Line "PR-65-NB" from Sta. 940+10.00 ("PR-A") to Sta. 975+45.00 ("PR-A").
 - For geometric information, see Geometric Layout Sheets.
 - For control point information, see Reference Tie Sheets.
 - Line "PR-A" to be constructed up to Sta. 940+10.00. Line "PR-65-SB" and Line "PR-65-NB" to be constructed from Sta. 940+10.00 to Sta. 975+45.00.

DRAFT
NOT FOR CONSTRUCTION

RECOMMENDED FOR APPROVAL	DESIGN ENGINEER	DATE
DESIGNED: JMA	DRAWN: CEB	
CHECKED: MKM	CHECKED: MKM	

INDIANA
DEPARTMENT OF TRANSPORTATION

PLAN SHEET
LINE "PR-A" - STA. 936+00 TO STA. 940+10
LINE "PR-65-SB AND LINE "PR-65-NB

HORIZONTAL SCALE	BRIDGE FILE
1"=50'	N/A
VERTICAL SCALE	DESIGNATION
N/A	2001172 & 2100049
SURVEY BOOK	SHEETS
ELECTRONIC	136 of 536
CONTRACT	PROJECT
R-42909	2001172 & 2100049

cebutler
 9/30/2020 3:23:55 pm
 model:Sheet10
 file:c:\cadd\ib\p\cebutler\gmatk\2001172-rd-s-pln01.dgn

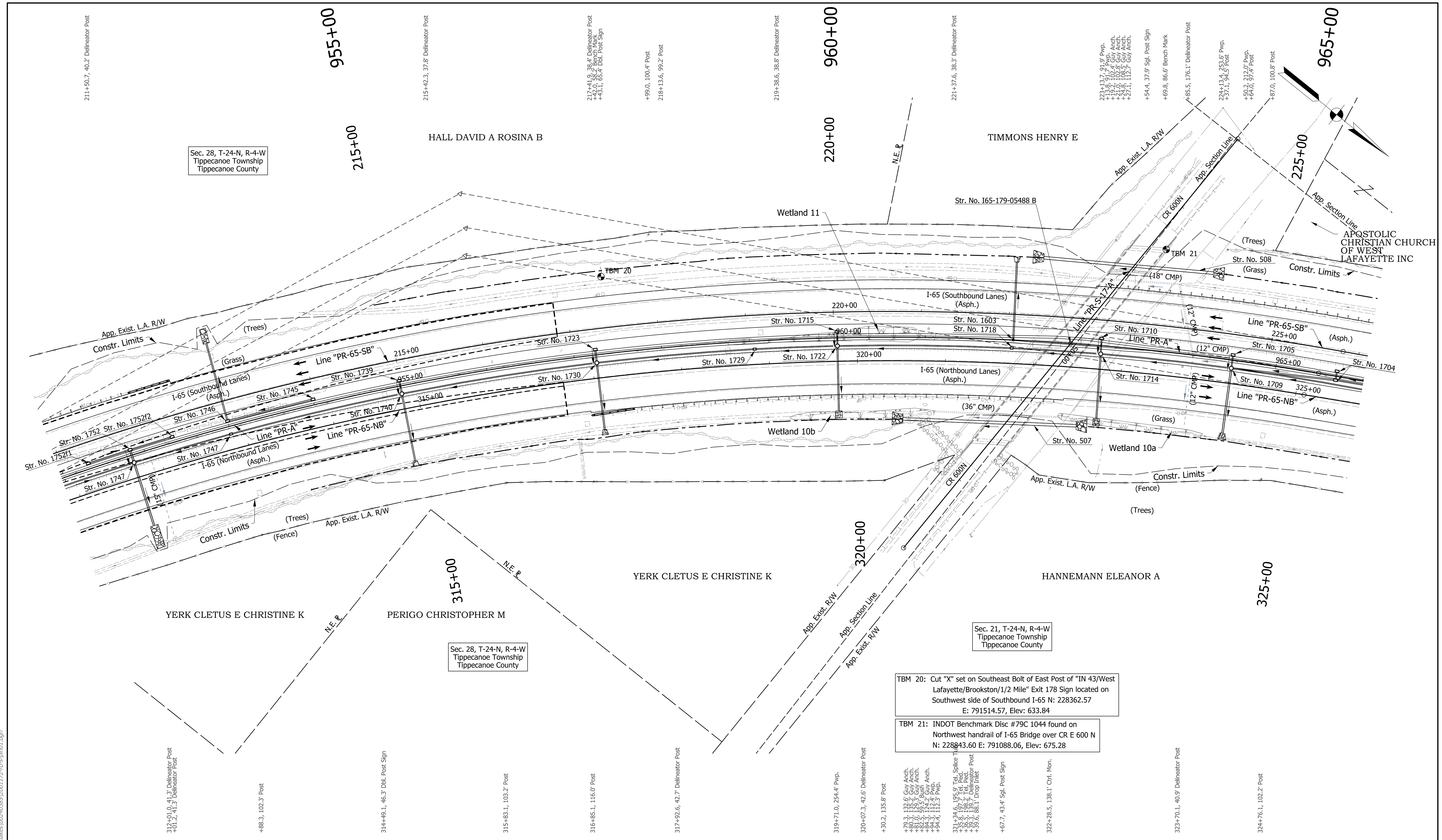

Sec. 28, T-24-N, R-4-W
Tippecanoe Township
Tippecanoe County

Sec. 21, T-24-N, R-4-W
Tippecanoe Township
Tippecanoe County

Sec. 28, T-24-N, R-4-W
Tippecanoe Township
Tippecanoe County

TBM 20: Cut "X" set on Southeast Bolt of East Post of "IN 43/West Lafayette/Brookston 1/2 Mile" Exit 178 Sign located on Southwest side of Southbound I-65 N: 228362.57
E: 791514.57, Elev: 633.84

TBM 21: INDOT Benchmark Disc #79C 1044 found on Northwest handrail of I-65 Bridge over CR E 600 N
N: 228843.60 E: 791088.06, Elev: 675.28

- Notes:**
- Existing topography notes taken from Line "PR-A" up to Sta. 940+10.00. Existing topography notes taken from Line "PR-65-SB" and Line "PR-65-NB" from Sta. 940+10.00 ("PR-A") to Sta. 975+45.00 ("PR-A").
 - For geometric information, see Geometric Layout Sheets.
 - For control point information, see Reference Tie Sheets.
 - Line "PR-A" to be constructed up to Sta. 940+10.00. Line "PR-65-SB" and Line "PR-65-NB" to be constructed from Sta. 940+10.00 to Sta. 975+45.00.

DRAFT
NOT FOR CONSTRUCTION

RECOMMENDED FOR APPROVAL	DESIGN ENGINEER	DATE
DESIGNED: JMA	DRAWN: CEB	
CHECKED: MKM	CHECKED: MKM	

INDIANA
DEPARTMENT OF TRANSPORTATION

PLAN SHEET
LINE "PR-65-SB" STA. 211+00 TO STA. 226+00
LINE "PR-65-NB" STA. 311+00 TO STA. 326+00

HORIZONTAL SCALE	BRIDGE FILE
1"=50'	N/A
VERTICAL SCALE	DESIGNATION
N/A	2001172 & 2100049
SURVEY BOOK	SHEETS
ELECTRONIC	139 of 536
CONTRACT	PROJECT
R-42909	2001172 & 2100049

cebutler
 9/30/2020 3:23:55 pm
 model:Sheet11
 file:c:\aditib\p\cebutler\gmatkakes\002\0385\2001172-rd-rs-pln01.dgn

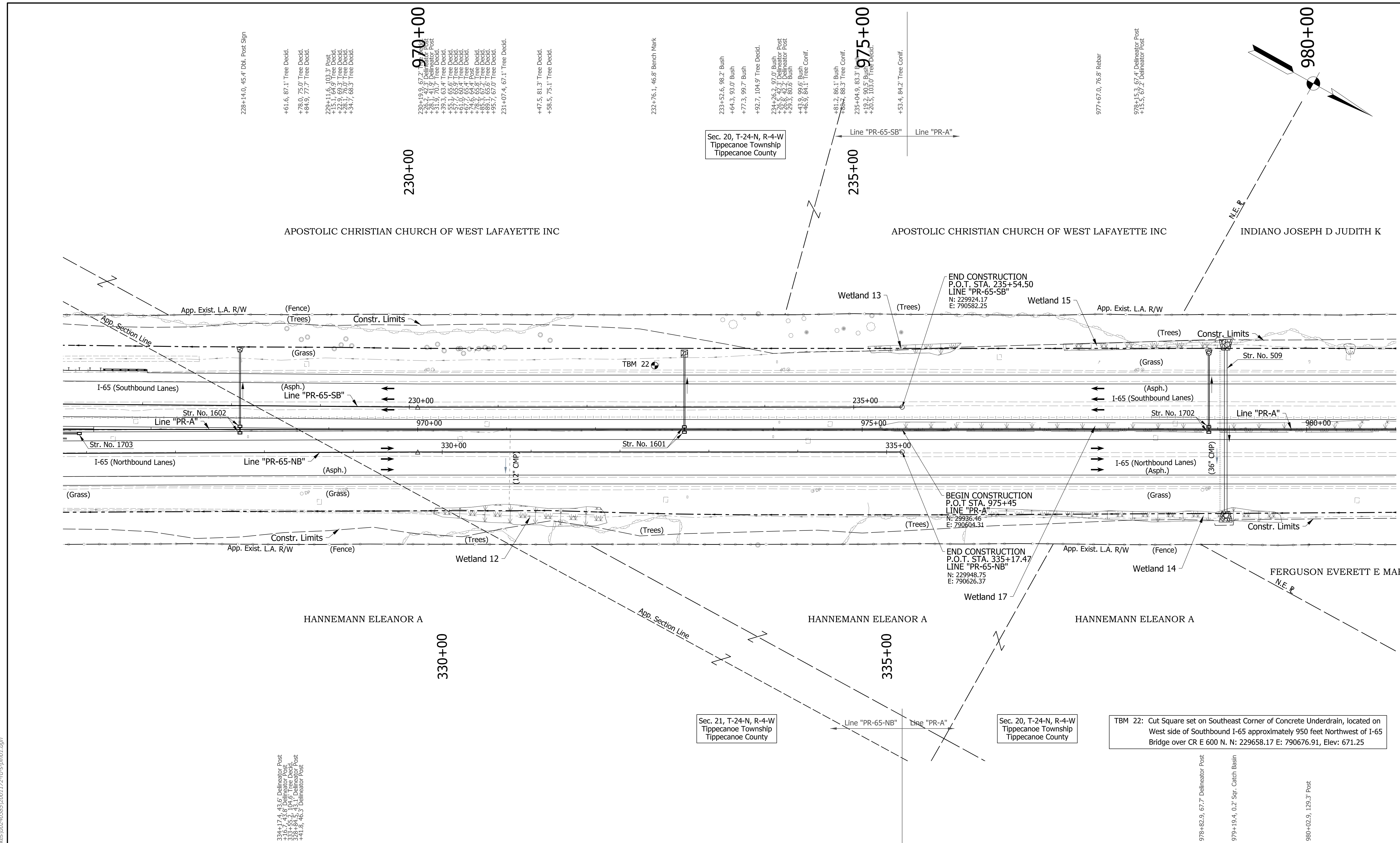

228+14.0, 45.4' Dbl. Post Sign
 +61.6, 87.1' Tree Decid.
 +78.0, 75.0' Tree Decid.
 +84.9, 77.7' Tree Decid.
 229+11.6, 03.3' Post
 +22.9, 69.3' Tree Decid.
 +28.1, 76.0' Tree Decid.
 +34.7, 68.3' Tree Decid.
 230+19.9, 67.2' Delineator Post
 +28.1, 41.9' Tree Decid.
 +39.3, 63.4' Tree Decid.
 +55.1, 65.6' Tree Decid.
 +57.7, 65.9' Tree Decid.
 +67.7, 65.4' Tree Decid.
 +74.6, 64.4' Tree Decid.
 +85.3, 67.2' Tree Decid.
 +89.7, 67.6' Tree Decid.
 231+07.4, 67.1' Tree Decid.
 +47.5, 81.3' Tree Decid.
 +58.5, 75.1' Tree Decid.

Sec. 20, T-24-N, R-4-W
 Tippecanoe Township
 Tippecanoe County

END CONSTRUCTION
 P.O.T. STA. 235+54.50
 LINE "PR-65-SB"
 N: 229924.17
 E: 790582.25

BEGIN CONSTRUCTION
 P.O.T. STA. 975+45
 LINE "PR-A"
 N: 29936.46
 E: 790604.31

END CONSTRUCTION
 P.O.T. STA. 335+17.47
 LINE "PR-65-NB"
 N: 229948.75
 E: 790626.37

TBM 22: Cut Square set on Southeast Corner of Concrete Underdrain, located on West side of Southbound I-65 approximately 950 feet Northwest of I-65 Bridge over CR E 600 N. N: 229658.17 E: 790676.91, Elev: 671.25

334+17.4, 43.6' Delineator Post
 333+55.2, 04.6' Tree Decid.
 338+84.5, 43.1' Delineator Post
 +41.6, 46.3' Delineator Post

978+82.9, 67.7' Delineator Post
 979+19.4, 0.2' Str. Catch Basin
 980+02.9, 129.3' Post

- Notes:**
- Existing topography notes taken from Line "PR-A" up to Sta. 940+10.00. Existing topography notes taken from Line "PR-65-SB" and Line "PR-65-NB" from Sta. 940+10.00 ("PR-A") to Sta. 975+45.00 ("PR-A").
 - For geometric information, see Geometric Layout Sheets.
 - For control point information, see Reference Tie Sheets.
 - Line "PR-A" to be constructed up to Sta. 940+10.00. Line "PR-65-SB" and Line "PR-65-NB" to be constructed from Sta. 940+10.00 to Sta. 975+45.00.

DRAFT
 NOT FOR CONSTRUCTION

RECOMMENDED FOR APPROVAL	DESIGN ENGINEER	DATE
DESIGNED: JMA	DRAWN: CEB	
CHECKED: MKM	CHECKED: MKM	

INDIANA
 DEPARTMENT OF TRANSPORTATION
 PLAN SHEET
 LINE "PR-65-SB AND LINE "PR-65-NB
 LINE "PR-A" - STA. 975+45 TO STA. 981+00

HORIZONTAL SCALE	BRIDGE FILE
1"=50'	N/A
VERTICAL SCALE	DESIGNATION
N/A	2001172 & 2100049
SURVEY BOOK	SHEETS
ELECTRONIC	141 of 536
CONTRACT	PROJECT
R-42909	2001172 & 2100049

cebutler
 9/30/2020 3:23:55 pm
 model:Sheet12
 file:c:\cadd\ib\p\cebutler\gmat\akes\002\0385\2001172-rd-s-pln01.dgn

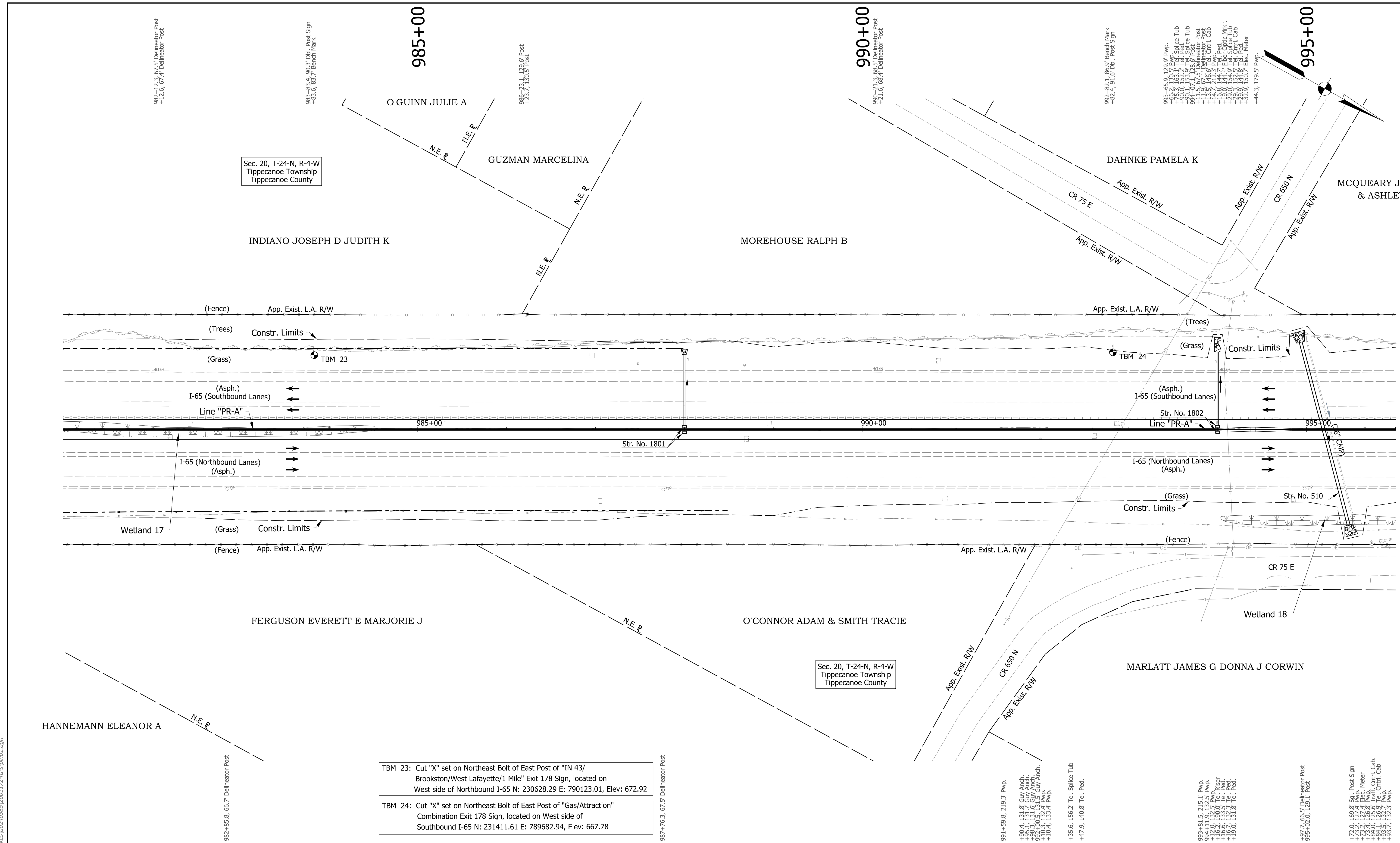

TBM 23: Cut "X" set on Northeast Bolt of East Post of "IN 43/ Brookston/West Lafayette/1 Mile" Exit 178 Sign, located on West side of Northbound I-65 N: 230628.29 E: 790123.01, Elev: 672.92

TBM 24: Cut "X" set on Northeast Bolt of East Post of "Gas/Attraction" Combination Exit 178 Sign, located on West side of Southbound I-65 N: 231411.61 E: 789682.94, Elev: 667.78

- Notes:**
- Existing topography notes taken from Line "PR-A".
 - For geometric information, see Geometric Layout Sheets.
 - For control point information, see Reference Tie Sheets.
 - Line "PR-A" to be constructed.

DRAFT
NOT FOR CONSTRUCTION

RECOMMENDED FOR APPROVAL	DESIGN ENGINEER	DATE
DESIGNED: JMA	DRAWN: CEB	
CHECKED: MKM	CHECKED: MKM	

INDIANA DEPARTMENT OF TRANSPORTATION

PLAN SHEET
LINE "PR-A"
STA. 981+00 TO STA. 996+00

HORIZONTAL SCALE	BRIDGE FILE
1"=50'	N/A
VERTICAL SCALE	DESIGNATION
N/A	2001172 & 2100049
SURVEY BOOK	SHEETS
ELECTRONIC	144 of 536
CONTRACT	PROJECT
R-42909	2001172 & 2100049

cebutler
 9/30/2020 3:23:55 pm
 model:Sheet13
 file: c:\cadd\ib\p\cebutler\greatakes\002\0385\2001172-rd-rs-pln01.dgn

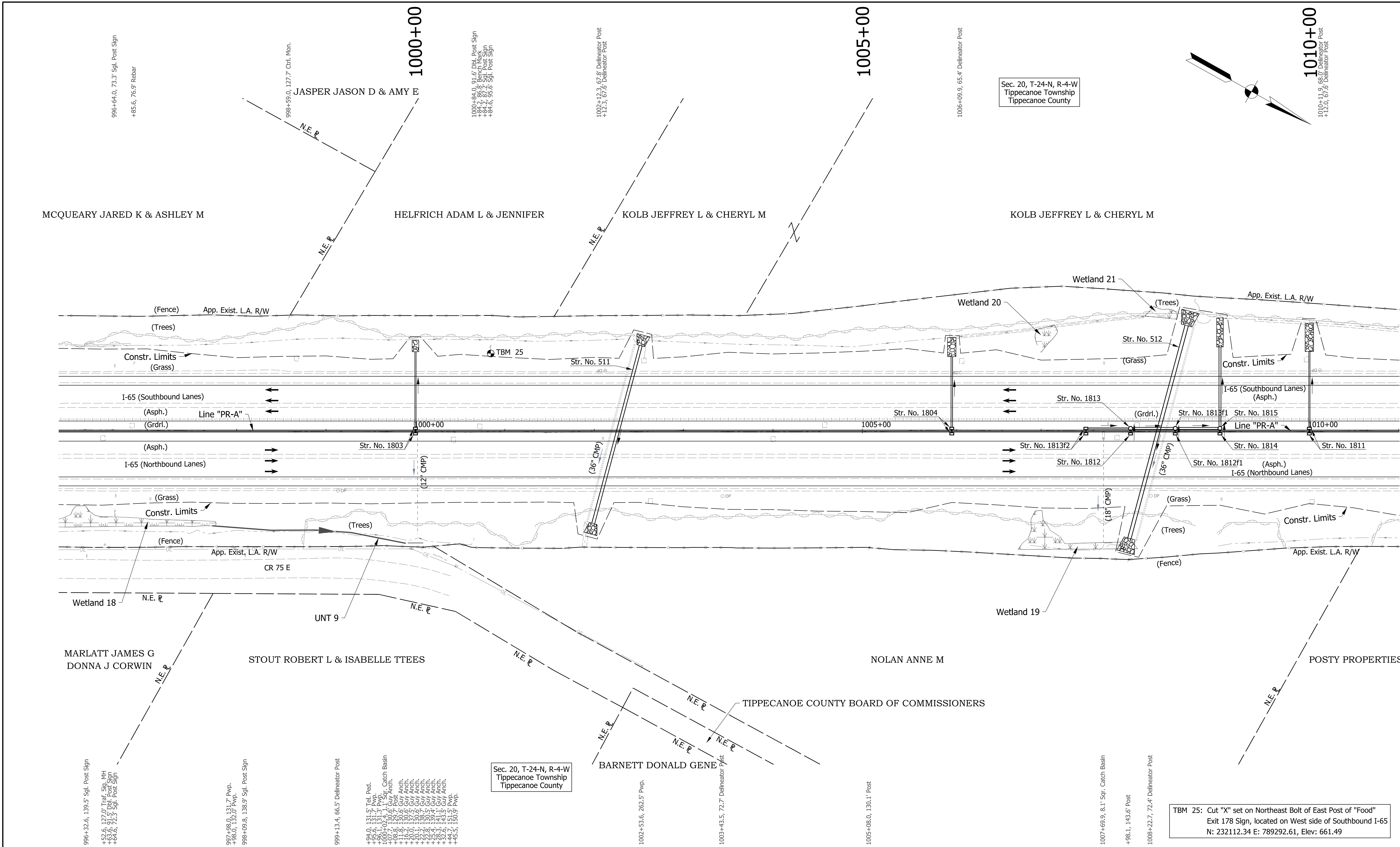

- Notes:**
- Existing topography notes taken from Line "PR-A".
 - For geometric information, see Geometric Layout Sheets.
 - For control point information, see Reference Tie Sheets.
 - Line "PR-A" to be constructed.

DRAFT
NOT FOR CONSTRUCTION

RECOMMENDED FOR APPROVAL	DESIGN ENGINEER	DATE
DESIGNED: JMA	DRAWN: CEB	
CHECKED: MKM	CHECKED: MKM	

INDIANA
DEPARTMENT OF TRANSPORTATION

PLAN SHEET
LINE "PR-A"
STA. 996+00 TO STA. 1011+00

HORIZONTAL SCALE	BRIDGE FILE
1"=50'	N/A
VERTICAL SCALE	DESIGNATION
N/A	2001172 & 2100049
SURVEY BOOK	SHEETS
ELECTRONIC	146 of 536
CONTRACT	PROJECT
R-42909	2001172 & 2100049

TBM 25: Cut "X" set on Northeast Bolt of East Post of "Food"
Exit 178 Sign, located on West side of Southbound I-65
N: 232112.34 E: 789292.61, Elev: 661.49

cebutler
 9/30/2020 3:23:55 pm
 model: Sheet14
 file: c:\cadd\ib\p\cebutler\gmat\kcs\002\0385\2001172-rd-rs-ph01.dgn

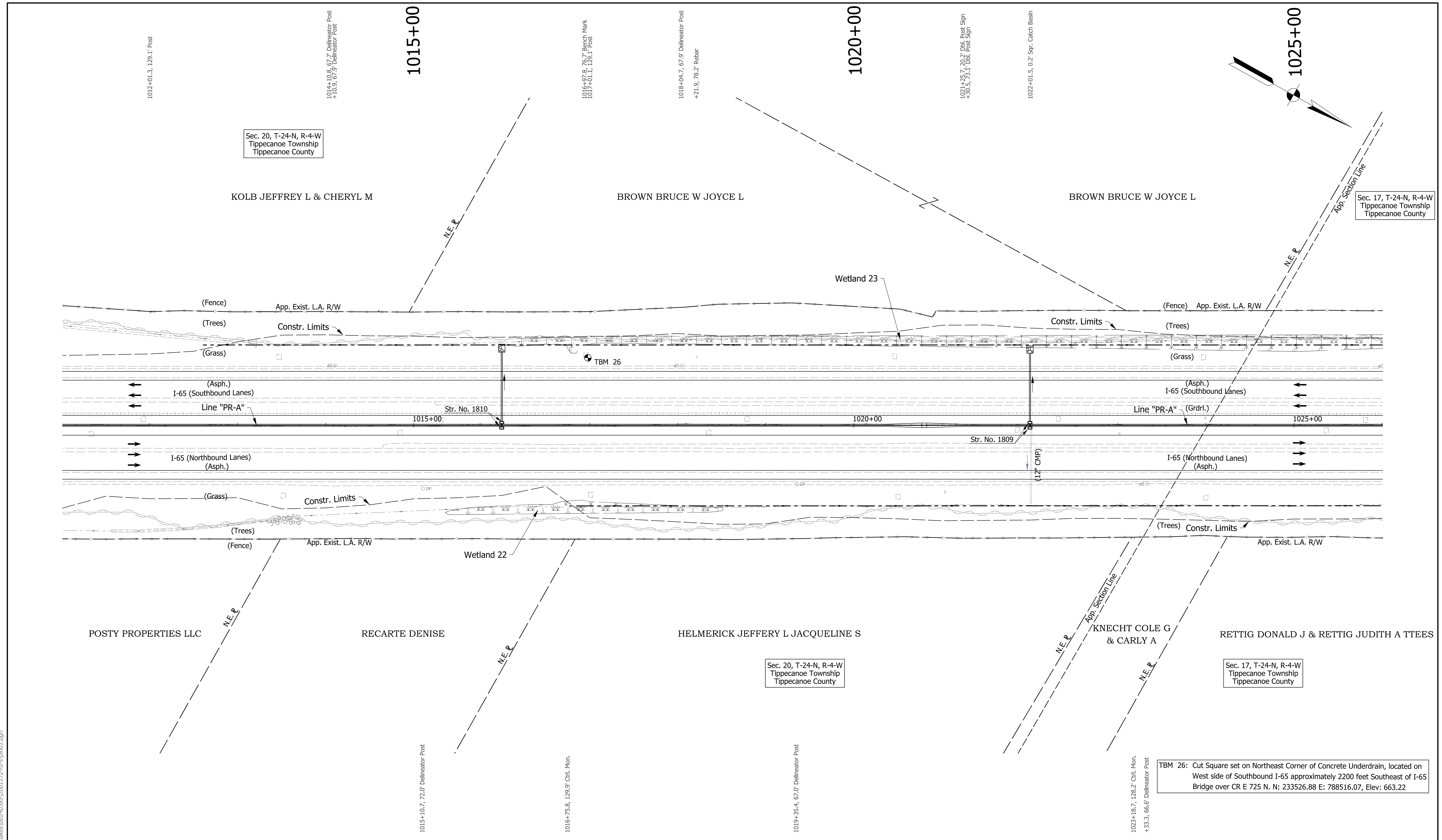

- Notes:**
- Existing topography notes taken from Line "PR-A".
 - For geometric information, see Geometric Layout Sheets.
 - For control point information, see Reference Tie Sheets.
 - Line "PR-A" to be constructed.

DRAFT
NOT FOR CONSTRUCTION

RECOMMENDED FOR APPROVAL	DESIGN ENGINEER	DATE
DESIGNED: JMA	DRAWN: CEB	
CHECKED: MKM	CHECKED: MKM	

INDIANA
DEPARTMENT OF TRANSPORTATION

PLAN SHEET
LINE "PR-A"
STA. 1011+00 TO STA. 1026+00

HORIZONTAL SCALE	BRIDGE FILE
1"=50'	N/A
VERTICAL SCALE	DESIGNATION
N/A	2001172 & 2100049
SURVEY BOOK	SHEETS
ELECTRONIC	148 of 536
CONTRACT	PROJECT
R-42909	2001172 & 2100049

TBM 26: Cut Square set on Northeast Corner of Concrete Underdrain, located on West side of Southbound I-65 approximately 2200 feet Southeast of I-65 Bridge over CR E 725 N. N: 233526.88 E: 788516.07, Elev: 663.22

cebutler
 9/30/2020 3:23:55 pm
 model: Sheet15
 file: c:\cadd\ib\p\cebutler\gmatdakes\002\0385\2001172-rd-s-pln01.dgn

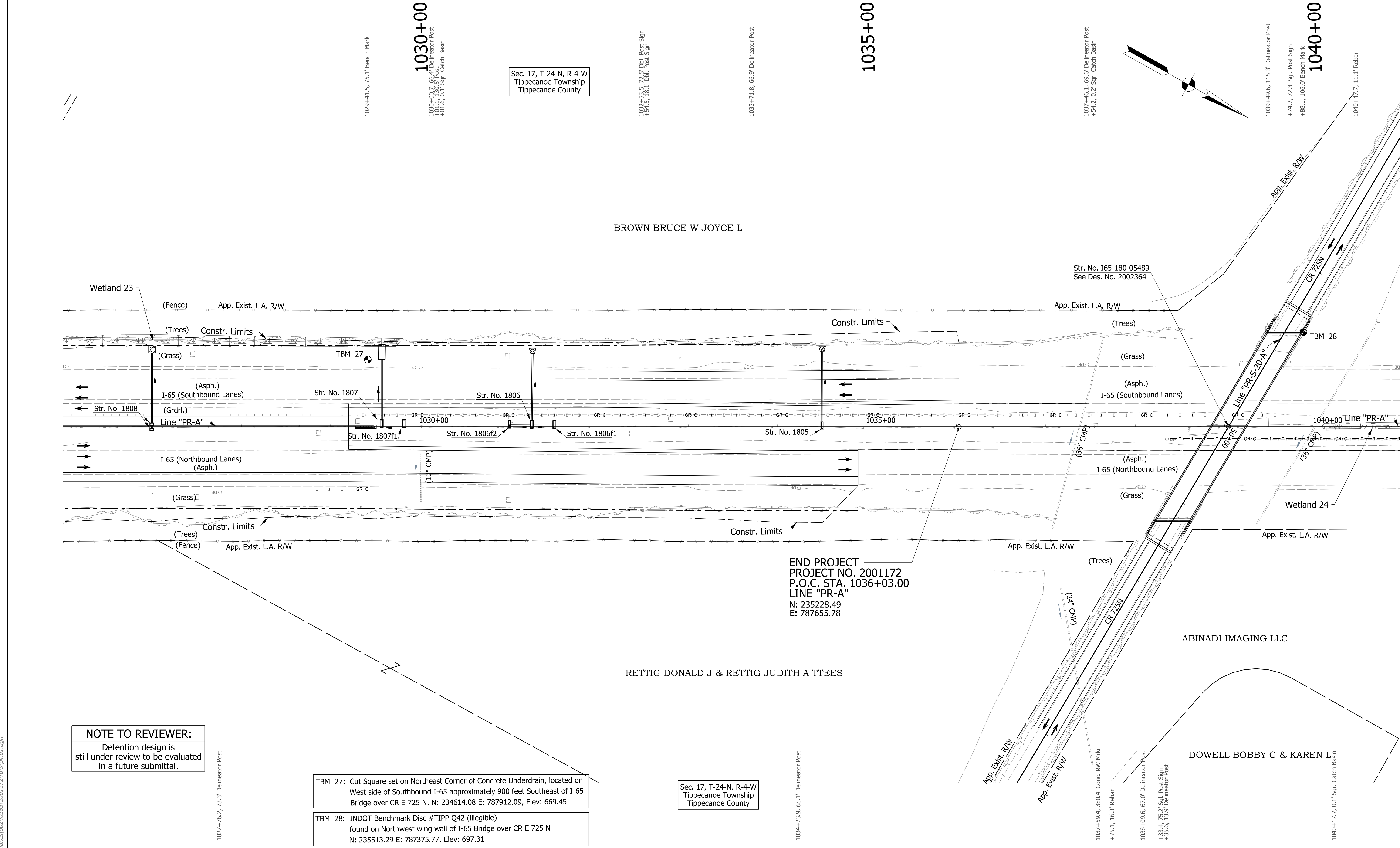

Sec. 17, T-24-N, R-4-W
Tippecanoe Township
Tippecanoe County

END PROJECT
PROJECT NO. 2001172
P.O.C. STA. 1036+03.00
LINE "PR-A"
N: 235228.49
E: 787655.78

NOTE TO REVIEWER:
Detention design is still under review to be evaluated in a future submittal.

TBM 27: Cut Square set on Northeast Corner of Concrete Underdrain, located on West side of Southbound I-65 approximately 900 feet Southeast of I-65 Bridge over CR E 725 N. N: 234614.08 E: 787912.09, Elev: 669.45

TBM 28: INDOT Benchmark Disc #TIPP Q42 (Illegible) found on Northwest wing wall of I-65 Bridge over CR E 725 N N: 235513.29 E: 787375.77, Elev: 697.31

DRAFT
NOT FOR CONSTRUCTION

RECOMMENDED FOR APPROVAL	DESIGN ENGINEER	DATE
DESIGNED: JMA	DRAWN: CEB	
CHECKED: MKM	CHECKED: MKM	

INDIANA
DEPARTMENT OF TRANSPORTATION

PLAN SHEET
LINE "PR-A"
STA. 1026+00 TO STA. 1041+00

HORIZONTAL SCALE	BRIDGE FILE
1"=50'	N/A
VERTICAL SCALE	DESIGNATION
N/A	2001172 & 2100049
SURVEY BOOK	SHEETS
ELECTRONIC	150 of 536
CONTRACT	PROJECT
R-42909	2001172 & 2100049

cebutler
9/30/2020 3:23:55 pm
model-Sheet16
file:c:\cadd\ib\p\cebutler\gmat\akes\002-03385\2001172-rd-s-pln01.dgn

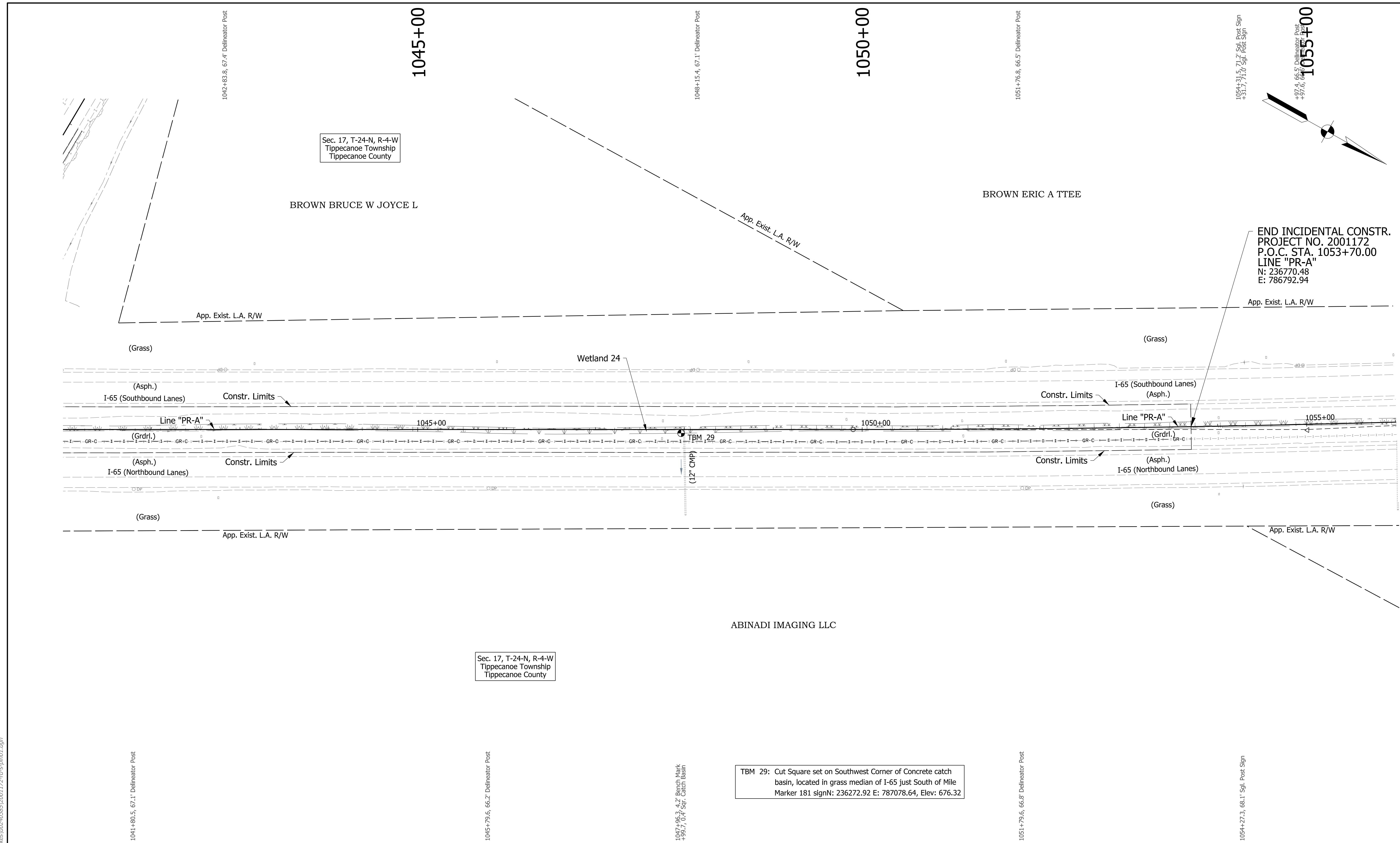

END INCIDENTAL CONSTR.
 PROJECT NO. 2001172
 P.O.C. STA. 1053+70.00
 LINE "PR-A"
 N: 236770.48
 E: 786792.94

TBM 29: Cut Square set on Southwest Corner of Concrete catch basin, located in grass median of I-65 just South of Mile Marker 181 signN: 236272.92 E: 787078.64, Elev: 676.32

- Notes:**
- Existing topography notes taken from Line "PR-A".
 - For geometric information, see Geometric Layout Sheets.
 - For control point information, see Reference Tie Sheets.
 - Line "PR-A" to be constructed.

DRAFT
 NOT FOR CONSTRUCTION

RECOMMENDED FOR APPROVAL _____	DESIGN ENGINEER _____	DATE _____
DESIGNED: _____ JMA _____	DRAWN: _____ CEB _____	
CHECKED: _____ MKM _____	CHECKED: _____ MKM _____	

INDIANA
 DEPARTMENT OF TRANSPORTATION

PLAN SHEET
 LINE "PR-A"
 STA. 1041+00 TO STA. 1056+00

HORIZONTAL SCALE	BRIDGE FILE
1"=50'	N/A
VERTICAL SCALE	DESIGNATION
N/A	2001172 & 2100049
SURVEY BOOK	SHEETS
ELECTRONIC	152 of 536
CONTRACT	PROJECT
R-42909	2001172 & 2100049

cebutler
 9/30/2020 3:23:55 pm
 model: Sheet17
 file: c:\cadd\ib\p\cebutler\gma\tales\02-10385\2001172-rd-rs-pln01.dgn