



DEPARTMENT OF THE ARMY
CHICAGO DISTRICT, U.S. ARMY CORPS OF ENGINEERS
231 SOUTH LA SALLE STREET, SUITE 1500
CHICAGO IL 60604

January 16, 2019

Planning Branch

Ms. Kathryn Vallis
IDNR Lake Michigan Coastal Program
1600 N 25 East
Chesterton, IN

Dear Ms. Vallis,

The United States Army Corp of Engineers, Chicago District is planning to undertake routine maintenance work on the Michigan City Harbor Breakwater (Enclosure 1). The purpose of this letter is to coordinate this action with your office under Section 307 of the Coastal Zone Management Act.

The proposed maintenance work consists of repairs to the eastern detached breakwater at the mouth of the harbor's entrance channel. The work on the breakwater will consist of repairing and restoring the structure through placing new and resetting existing armor stone. This work will occupy the same cross-sectional area as the current breakwater.

The original breakwater was constructed in 1903 with the concrete superstructure added in 1923. Riprap was placed in 1939-40 and in 1968-69. The concrete cap was reconstructed in 1978. Periodic maintenance work has occurred repeatedly over the years, the extent of which is dependent on need and severity of degradation. Therefore, the boundaries shown on the figure show the extent possible over the life of the project. It is anticipated that the proposed activity complies with Indiana's approved coastal management program and will be conducted in a manner consistent with such program. Since this is an on-going maintenance project for a Federal Breakwater, the Chicago District requests a General Federal Consistency Determination for the life of the project. If maintenance areas change in the future, the Chicago District will request a new determination.

Any questions regarding this letter can be directed to Mr. John Belcik, District Planner, at 312-846-5595 or at john.t.belcik@usace.army.mil.

Sincerely,

A handwritten signature in black ink that reads "Susanne J. Davis". The signature is written in a cursive style.

Susanne J. Davis, P.E.
Chief, Planning Branch

Enclosure



Michigan City Breakwater Repairs FY20

U.S. ARMY CORPS OF ENGINEERS
CHICAGO DISTRICT





Michigan City Harbor, IN

US Army Corps
of Engineers®
Chicago District

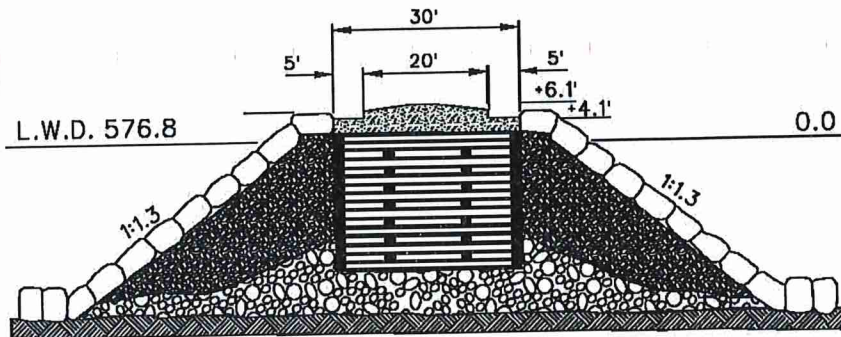

DETACHED BREAKWATER

REACH A
YEAR OF COMPLETION 1903
CONCRETE SUPR BUILT 1923
RIP RAP PLACED 1939-40
CONCRETE CAP REBUILT 1978

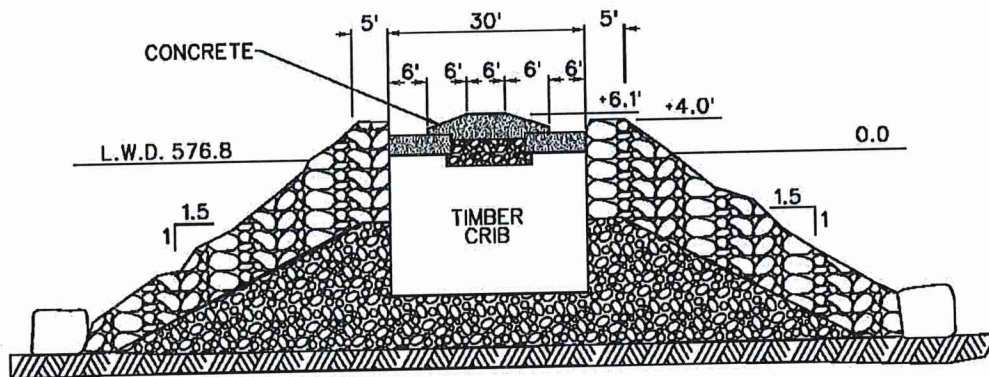

DETACHED BREAKWATER

REACH B
YEAR OF COMPLETION 1903
CONCRETE SUPR BUILT 1925
RIP RAP PLACED 1968-69

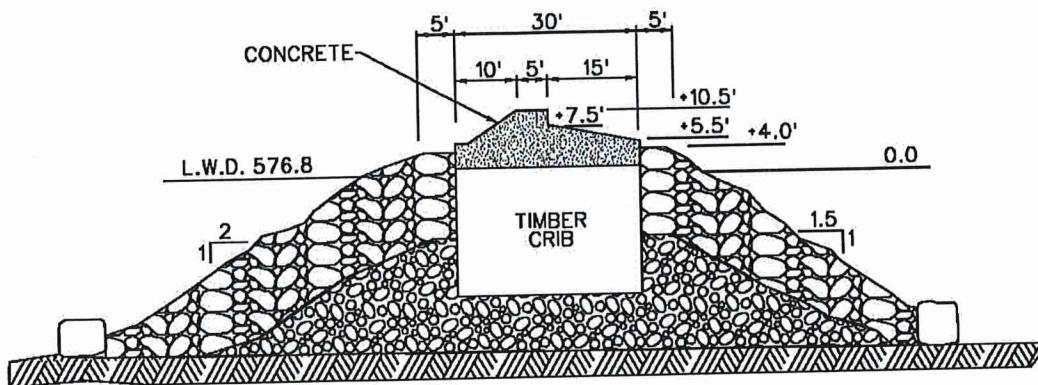

DETACHED BREAKWATER

REACH C
YEAR OF COMPLETION 1903
CONCRETE SUPR BUILT 1911
RIP RAP PLACED 1968-69



SCALE: 1" = 30'-0"

Tribal Historic Preservation Officer Kelli Mosteller
Citizen Potawatomi Nation, Oklahoma
1899 S. Gordon Cooper Drive
Shawnee, OK

Tribal Historic Preservation Officer Diane Hunter
Miami Tribe of Oklahoma
PO Box 1326
Miami, OK

Tribal Historic Preservation Officer Wesley Andrews
Little Traverse Bay Bands of Odawa Indians, Michigan
7500 Odawa Circle
Harbor Springs, MI

Tribal Historic Preservation Officer Matt Bussler
Pokagon Band of Potawatomi Indians, Michigan and Indiana
58620 Sink Road
Dowagiac, MI

Chairperson Kenneth Meshigaud
Hannahville Indian Community, Michigan
N14911 Hannahville B1 Road
Wilson, MI

Chairperson Liana Onnen
Prairie Band Potawatomi Nation
16281 Q Road
Mayetta, KS

Assistant Director of Environmental Review Chad Slider
IDNR Division of Historic Preservation and History
402 W. Washington Street, Rm W274
Indianapolis, IN

Biologist Elizabeth McCloskey
U.S. Fish & Wildlife Service
P.O. Box 2616
Chesterton, IN

Chairman John Barrett
Citizen Potawatomi Nation, Oklahoma
1601 South Gordon Cooper Drive
Shawnee, OK

Chief Douglas Lankford
Miami Tribe of Oklahoma
PO Box 1326
Miami, OK

Chairperson Regina Gasco-Bentley
Little Traverse Bay Bands of Odawa Indians, Michigan
7500 Odawa Circle
Harbor Springs, MI

Chairperson Matt Wesaw
Pokagon Band of Potawatomi Indians, Michigan and Indiana
PO Box 180
Dowagiac, MI

Tribal Historic Preservation Officer Thomas Wabmum
Prairie Band Potawatomi Nation
16281 Q Road
Mayetta, KS

Tribal Historic Preservation Officer Harold Frank
Forest County Potawatomi Community of Wisconsin
P.O. Box 340
Crandon, WI

Coastal Resources Planner Kathryn Vallis
IDNR Lake Michigan Coastal Program
1600 N 25 East
Chesterton, IN